

M01



- STERILE INSTRUMENT PACKAGING TABLES
- STERILE INSTRUMENT PACKAGING FURNITURE
- CSSD LOGISTIC
- SHELVING FOR STORAGE
- BASKETS, CONTAINERS AND SHELVES



# DIVISION



- M01** TAVOLI PER CONFEZIONAMENTO STRUMENTARIO STERILE - ARREDI PER CONFEZIONAMENTO STRUMENTARIO STERILE  
LOGISTICA PER CENTRALI DI STERILIZZAZIONE - SCAFFALATURA DI DEPOSITO E STOCCAGGIO - PANIERI GRIGLIATI,  
CONTENITORI E RIPIANI  
STERILE INSTRUMENT PACKAGING TABLES - STERILE INSTRUMENT PACKAGING FURNITURE - CSSD LOGISTIC  
SHELVING FOR STORAGE - BASKETS, CONTAINERS AND SHELVES
- M02** ARMADI DI DEPOSITO E STOCCAGGIO - CARRELLI ARMADIO PER TRASPORTO STRUMENTARIO - ARMADI PASSANTI  
CABINETS FOR STORAGE - MOBILE INSTRUMENT CABINETS - PASS THROUGH CABINETS
- M03** ARREDO PRE SALA OPERATORIA - LOGISTICA PER SALA OPERATORIA - SGABELLI E SELLE  
CARRELLI PER TRASPORTO FARMACEUTICO - SCAFFALATURA DEPOSITO FARMACEUTICO - CARRELLI GESTIONE RIFIUTI OSPEDALIERI  
PRE-SURGICAL FURNITURE THEATRE - SURGICAL THEATRE LOGISTICS - STOOLS & SADDLES  
PHARMACEUTICAL TRANSPORT TROLLEYS - PHARMACEUTICAL SHELVING STORAGE - WASTE MANAGEMENT TROLLEYS

## INDICE - INDEX

- PAG 06** TAVOLI PER CONFEZIONAMENTO STRUMENTARIO STERILE  
TECHNICAL TABLES FOR PACKING STERILE TOOLS



- PAG 16** ARREDI PER CONFEZIONAMENTO STRUMENTARIO STERILE  
TECHNICAL FURNITURE FOR PACKING STERILE TOOLS



- PAG 24** LOGISTICA PER CENTRALI DI STERILIZZAZIONE  
LOGISTICS FOR CSSD



- PAG 32** SCAFFALATURE DI DEPOSITO E STOCCAGGIO  
SHELVING UNITS

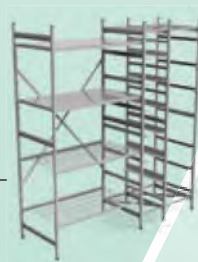

- PAG 46** PANIERI GRIGLIATI, CONTENITORI E RIPIANI  
BASKETS, CONTAINERS AND SHELVES



# LEGENDA LEGEND

**ISO** **DIN** **SPRI**  
mm 600x400 mm 600x300 mm 600x400

## STRUCTURAL DETAILS

**AISI 304**  
Struttura in acciaio inox  
Stainless steel structure  
Gestell aus Edelstahl  
Structure en acier inoxydable  
Estructura de acero inoxidable

**AI**  
ALUMINIUM  
Struttura in alluminio  
Aluminum structure  
Gestell aus Aluminium  
Structure en aluminium  
Estructura de aluminio

**ALU**  
LIGHT CHASSIS  
Chassis in lega leggera  
Light alloy chassis  
Gehäuse aus Leichtaluminium  
Châssis en alliage léger  
Chasis de aleación ligera

**STEEL**  
HEAVY CHASSIS  
Chassis in acciaio zincato  
Galvanized steel chassis  
Gehäuse aus verzinktem Stahl  
Châssis en acier galvanisé  
Chasis de acero cincado

**P**  
POLYPROPYLENE  
Struttura in polipropilene  
Polypropylene structure  
Struktur aus Polypropylen  
Structure en polypropylène  
Estructura de polipropileno

**FIXED**  
Ruote fisse  
Fixed wheels  
Feste Rollen  
Roues fixes  
Ruedas fijas

**AISI 304**  
INOX CHASSIS  
Chassis in acciaio inox  
Stainless steel chassis  
Gehäuse aus Edelstahl  
Châssis en acier inox  
Chasis de acero inoxidable

**BRAKE**  
Ruote girevoli con freno  
Swivel wheels with brake  
Lenkrollen mit Bremse  
Roues pivotante avec frein  
Ruedas giratorias con freno

**PLASTIC BASE**  
Base in plastica contenitiva  
Plastic base plate  
Kunststoffgrundlage  
Base en plastique de maintien  
Base de plástico de contención

**SWIVEL**  
Ruote girevoli  
Swivel wheels  
Lenkrollen  
Roues pivotantes  
Ruedas giratorias

**RIB**  
Nervatura di rinforzo ogni 120mm  
Reinforcement ribs  
Verstärkungsrippen  
Nervures de renforcement  
Nervios de refuerzo

**LAMINATED**  
Truciolare nobilitato laminato  
Laminated particleboard body  
Body mit Edelholz-Abschluss  
Corps en aggloméré plaqué  
Cuerpo de aglomerado ennoblecido

**RUBBER INJ**  
Anello in gomma iniettata  
Injected rubber ring  
Gespritzter Gummiring  
Anneaux en caoutchouc injecté  
Anillo de goma inyectada

## SAFETY DETAILS

**BUMPER**  
Paracolpi circolari  
Circular rubber buffer  
Runde Puffer  
Butoirs circulaires  
Topes circulares

**PVC BUMPER**  
Paraurti in PVC  
PVC bumper  
Stoßleiste aus PVC  
Pare-chocs en PVC  
Topes de PVC

**PEHD BUMPER**  
Paraurti in PEHD  
HDPE bumper  
Stoßleiste aus PEHD  
Pare-chocs en PEHD  
Topes de PEHD

**NO INFILTRATION**  
Nessuna infiltrazione  
No infiltration  
Keine Infiltration  
Pas d'infiltration  
Ninguna infiltración

**NO DIRT**  
No depositi di sporco  
No dirt deposit  
Der Schmutz kann sich nicht anlagern  
Pas de saleté  
Sin depósitos de suciedad

**SANITIZER**  
Sanificabile/lavabile  
Sanitary/washable  
Sterilisierfähig/Waschbar  
Ils peuvent être assainis/nettoyés  
Sanificable/lavable

**SOFT**  
Chiusura non rumorosa  
Silent closing  
Leises Schließen  
Fermeture non bruyante  
Cierre silencioso

**WATERTIGHT**  
Tenuta stagna  
Watertight  
Dicht  
Étanche  
Impermeable

**JOINT**  
Senza giunzioni  
Without joins  
Ohne Verbindungen  
Sans jonctions  
Sin juntas

## TECHNICAL DETAILS

**EXTRACTABLE**  
Ripiani ribaltabili ed estraibili  
Removable/folding shelves  
Herausnehmbare/klappbare Zwischenböden  
Étagères amovibles/repliables  
Esteranterías extraíbles/abatibles

**INTERNAL**  
Rack interno con guide  
Interior rack with slides  
Innen Rack mit Leisten  
Rack intérieur avec guides  
Rack interno con guías

**TIG**  
Saldatura a TIG  
TIG welding  
Schweißung mit TIG-Verfahren  
Soudure en TIG  
Soldadura de TIG

**DISMANTLE**  
Fornibili smontati  
Supplied for assembling  
Demontiert Lieferbar  
Ils peuvent être fournis démontés  
Se entregan sin montar

**OVERTURN**  
Sportello ribaltabile  
Tilting door  
Klappbare Wand  
Porte escamotable  
Portezuela abatible

**REMOVABLE**  
Rack interno asportabile  
Removable interior rack  
Herausnehmbares Rack  
Rack intérieur démontable  
Rack interno desmontable

**An**  
ANODIZED  
Alluminio anodizzato  
Anodized finish  
Anodisierte Oberflächenbehandlung  
Finition d'anodisation  
Acabado de anodización

**STOPPER**  
Magneti di bloccaggio  
Clamping magnet  
Magnet zum Sperren  
Magnéto de blocage  
Imán de bloqueo

**270°**  
Porte apribili a 270°  
Door opening to 270°  
Öffnung der Türen bis hin zu 270°  
Puertas abribles a 270°

**DOUBLE**  
Chiusura doppio bloccaggio  
Double locking closure  
Doppelte Schließung  
Fermeture double blocage  
Cierre de doble bloqueo

**MANUAL**  
Elevazione manuale  
Manual lifting  
Manuelle Erhöhung  
élévation manuelle  
Elevación manual

**AUTOMATIC**  
Elevazione automatica  
Electrical lifting  
Elektrische Erhöhung  
élévation électrique  
Elevación eléctrica

**ANTISTATIC**  
Antistatico  
Anti-static  
Antistatisch  
Antistatique  
Antiestático

**ERGONOMIC**  
Seduta ergonomica  
Ergonomic seating  
Ergonomischer Sitz  
Assis ergonomique  
Asiento ergonómico

## RICERCA E SVILUPPO R&D DEPARTMENT



 Nel nostro ufficio R&D di Travagliato lavora uno staff dalla filosofia progettuale ben precisa, che punta a ristabilire l'equilibrio tra design, concetto e funzionalità.

Nel reparto produttivo, acciaio ed alluminio sono realizzati da personale altamente specializzato con processi di lavorazione di grande precisione che rappresentano da 50 anni questa realtà produttiva.

 The staff of our R&D department in Travagliato work according to a strictly-defined design philosophy aimed at restoring the balance between design, concept and functionality.

In our manufacturing plant highly skilled workers forge steel and aluminum using ultra-precise processes that have been the company trademark for 50 years.

 In unserer R&D Abteilung in Travagliato arbeitet ein Team mit einer genauen Planungsphilosophie, mit dem Ziel das Gleichgewicht zwischen Design, Konzept und Funktionalität wiederherzustellen.

In unserer Produktionsabteilung werden Stahl und Aluminium von hoch qualifiziertem Personal zusammen mit den feinsten Arbeitsprozessen geschmiedet, die seit 50 Jahren diese Fertigungs-wirklichkeit darstellen.

 L'équipe qui forme notre service de recherche et développement de Travagliato adopte une approche visant à établir un équilibre entre design, concept et fonctionnalités.

Dans nos ateliers, l'acier et l'aluminium sont réalisés par des spécialistes utilisant des technologies de pointe qui ont fait de cette production une réalité depuis 50 ans.

 En nuestro departamento de R&D de Travagliato trabaja una plantilla con una filosofía de proyecto muy precisa, la cual persigue restablecer el equilibrio entre diseño, concepto y funcionalidad.

En la sección de producción, personal altamente especializado hace acero y aluminio mediante procesos de elaboración de gran precisión los cuales representan esta realidad productiva desde hace 50 años.





- RICERCA, INNOVAZIONE E PERSONALIZZAZIONE rappresentano il miglior potenziale di sviluppo.
- RESEARCH, INNOVATION AND CUSTOMIZATION have represent the best development potential.
- Seit jeher stellen FORSCHUNG, INNOVATION UND KUNDENORIENTIERUNG das beste Entwicklungspotential dar.
- LA RECHERCHE, L'INNOVATION ET LA PERSONNALISATION sont au cœur de notre potentiel de croissance.
- INVESTIGACIÓN, INNOVACIÓN Y PERSONALIZACIÓN representan el mejor potencial de desarrollo.





SCAFFALATURE DI DEPOSITO E STOCCAGGIO **PAG 32**  
SHELVING UNITS



TAVOLI PER CONFEZIONAMENTO **PAG 06**  
STRUMENTARIO STERILE  
TECHNICAL TABLES FOR PACKING  
STERILE TOOLS



PANIERI GRIGLIATI, CONTENITORI E RIPIANI **PAG 46**  
BASKETS, CONTAINERS AND SHELVE



LOGISTICA PER CENTRALI DI STERILIZZAZIONE **PAG 24**  
LOGISTICS FOR CSSD



SCAFFALATURE DI DEPOSITO E STOCCAGGIO **PAG 32**  
SHELVING UNITS



SOILED RECEIVE  
& SORT



CLEAN INSPECT  
& PACK



STERILE STORE  
& DISTRIBUTE





**PAG 16** ARREDI PER CONFEZIONAMENTO STRUMENTARIO STERILE  
TECHNICAL FURNITURE FOR PACKING STERILE TOOLS



**PAG 10** CARRELLI ARMADIO PER TRASPORTO STRUMENTARIO  
MOBILE INSTRUMENT CABINETS  
**PAG 28** CARRELLI ARMADIO IN LEGA LEGGERA PER IL TRASPORTO STRUMENTARIO  
LIGHT ALLOY TROLLEYS FOR TOOL TRANSPORT



DIRTY INSTRUMENTS  
RECEPTION

CLEAN INSTRUMENTS  
DISTRIBUTION



**PAG 10** CARRELLI ARMADIO PER  
TRASPORTO STRUMENTARIO  
MOBILE INSTRUMENT  
CABINETS

**PAG 28** CARRELLI ARMADIO IN  
LEGA LEGGERA PER IL  
TRASPORTO STRUMENTARIO  
LIGHT ALLOY TROLLEYS FOR  
TOOL TRANSPORT



**PAG 04** ARMADI DI DEPOSITO E STOCCAGGIO  
FILING AND STORAGE CABINETS



**PAG 34** ARMADI PASSANTI  
PASS THROUGH CABINETS

## TAVOLI PER CONFEZIONAMENTO STRUMENTARIO STERILE. TECHNICAL TABLES FOR PACKING STERILE TOOLS.

- Adatti al confezionamento e preparazione dei panieri grigliati e containers adibiti al contenimento dello strumentario chirurgico da sterilizzare.
- Suitable for packaging and preparation of wire trays and containers used to contain the surgical instruments to be sterilized.
- Geeignet für die Verpackung und Vorbereitung der Gitterkörbe und Behälter für die Aufnahme der zu sterilisierenden chirurgischen Instrumente.
- Convient pour l'emballage et la préparation des paniers grillagés et des conteneurs utilisés pour le confinement des instruments chirurgicaux destinés à être stérilisés.
- Aptas para el envasado y la preparación de las cestas enrejadas y contenedores que contienen el instrumental quirúrgico por esterilizar.

 Costruiti con struttura portante in profilati quadri da 35x35 mm e lamiera di acciaio inox AISI 304 (1.4301) con finitura superficiale Scotch-Brite.

Piano superiore in lamiera completamente liscia e piana, con spigoli arrotondati, supportato nella parte sottostante da un pannello anti vibrazioni.

Tutte le saldature vengono eseguite con procedimento TIG robotizzato, senza fessure ed interstizi, facilitando così le operazioni di lavaggio, disinfezione e pulizia, a garanzia della massima igiene.

 Built of a frame made of 35 x 35 mm square section bars and AISI 304 (1.4301) stainless steel sheet with Scotch-Brite surface finish.

Upper surface made of completely smooth and flat sheet metal, with rounded corners, supported underneath by an anti-vibration panel.

All welds are done using a robotic TIG process, without cracks and gaps, facilitating washing, cleaning and disinfection operations, to ensure maximum hygiene.

 Hergestellt mit tragender Struktur aus quadratischem Profilmaterial 35x35 mm und Edelstahlblech AISI 304 (1.4301) mit Oberflächenbearbeitung Scotch-Brite.

Obere Fläche aus Blech, vollständig glatt und eben, mit abgerundeten Kanten, mit schwingungsdämpfender Auflage im unterem Bereich.

Alle Schweißarbeiten werden mit robotisiertem TIG-Verfahren ohne Schlitze oder Zwischenräume ausgeführt und erleichtern so die Reinigungs- und Desinfektionsarbeiten. Auf diese Weise wird umfassende Hygiene gewährleistet.



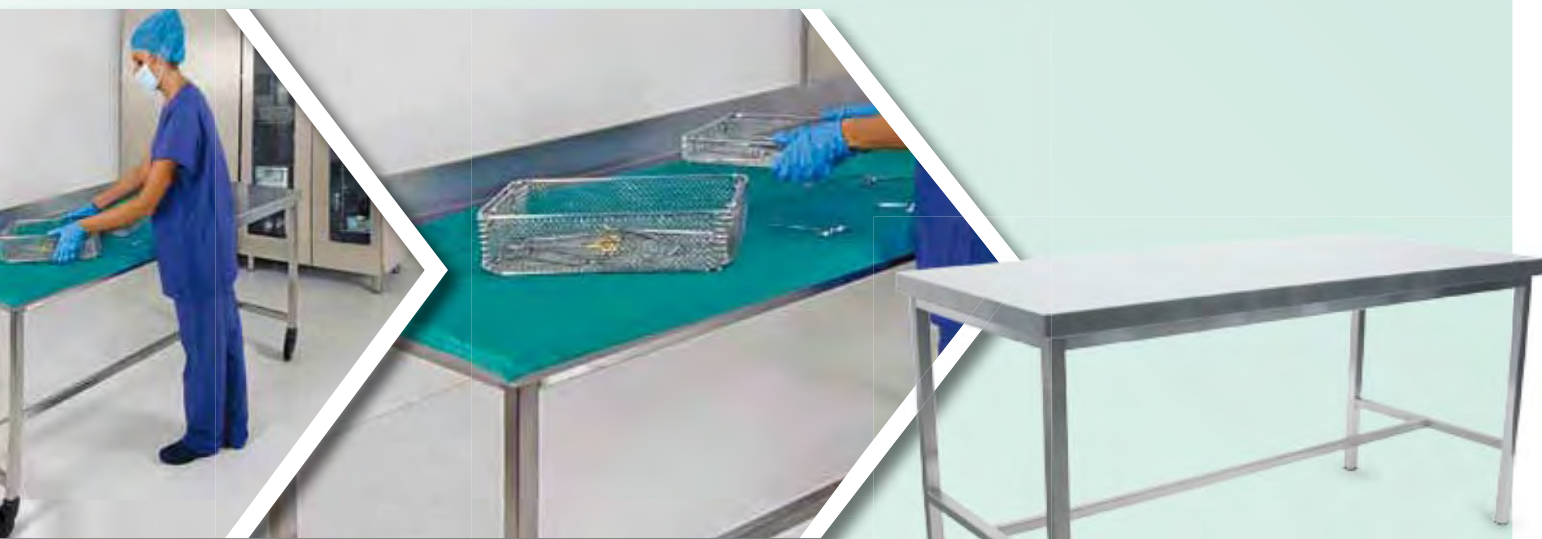

 Fabriqué avec une structure portante en profilés, cadres de 35x35 mm et tôle d'acier inoxydable AISI 304 (1.4301) avec finition de surface Scotch-Brite.

Plan supérieur en tôle complètement lisse et plate, avec angles arrondis, soutenu par un panneau anti-vibrations dans la partie sous-jacente.

Toutes les soudures sont effectuées selon la procédure automatisée TIG, sans fissures ni interstices, facilitant ainsi les opérations de lavage, de désinfection et de nettoyage, garantissant donc un maximum d'hygiène.

 Construido con estructura portante de perfiles cuadrados de 35x35 y chapa de acero inoxidable AISI 304 (1.4301) con acabado superficial Scotch-Brite.

Plano superior de chapa completamente lisa y plana, con ángulos redondeados, soportado en la pared subyacente por un panel anti-vibraciones.

Todas las soldaduras son realizadas con procedimiento TIG robotizado, sin grietas ni intersticios, facilitando de este modo las operaciones de lavado, desinfección y limpieza, para garantizar máxima higiene.

# TAVOLI PER CONFEZIONAMENTO STRUMENTARIO STERILE TECHNICAL TABLES FOR PACKING STERILE TOOLS

OPTIONALS

## STRUCTURAL DETAILS:



## SAFETY DETAILS:



## TECHNICAL DETAILS:



LGH-191 • Lampada a LED  
• LED lamp.



LP-191 • Lampada con lente d'ingrandimento.  
• Magnifier lamp.

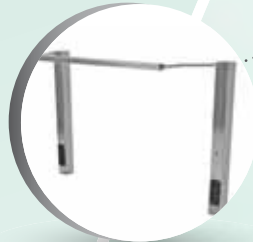

CL-191 • Colonna elettrica.  
• Electric plugs.



BH-191 • Supporto cesti laterale.  
• Side basket support.



DR-191-1



DR-191-2



DR-191-3

- Cassettiera 1-2-3 cassetti.
- Chest 1-2-3 drawers.





- Ruote antistatiche.
- Antistatic Wheels.



- Piano in Corian.
- Corian surface.

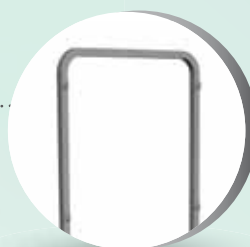
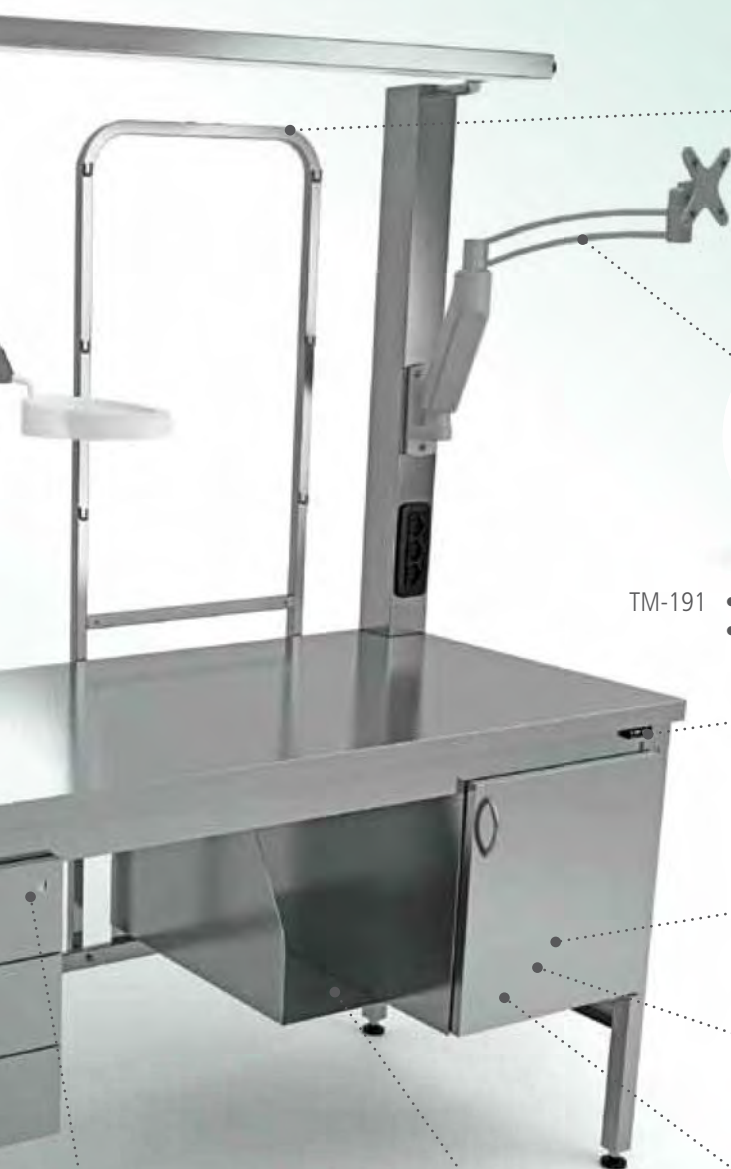

- MF-191 • Supporto accessori (vedi Pagina 10).  
• Accessories handling (view page10).

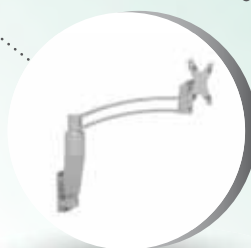

- TM-191 • Braccio porta-monitor/tastiera.  
• Screen/keyboard arm holder.



- MP-191 • Memoria 4 posizioni  
• 4 position present memory



- RP-191 • Supporto ripiano regolabile.  
• Height adjustable shelf support.

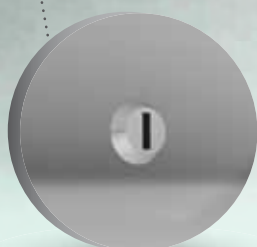

- DRLOCK • Serratura.  
• Lock.

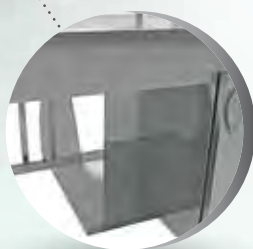

- PC-191 • Porta PC.  
• PC holder.

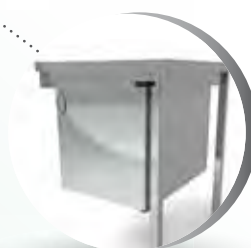

- VP-191 • Armadietto.  
• Cupboard.

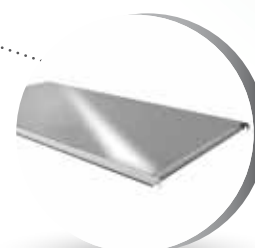

- LS-191 • Ripiano.  
• Shelf.



# TAVOLI PER CONFEZIONAMENTO STRUMENTARIO STERILE

## TECHNICAL TABLES FOR PACKING STERILE TOOLS

ACCESSORIES



AX05 • Dispenser.  
• Tilt bins.



AX-16 • Supporto obliquo cesti.  
• Inclined basket support.



CPALFA • Contenitore.  
• Container.

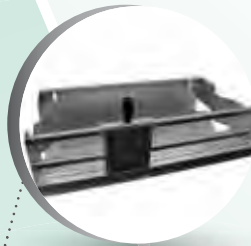

CUT-191 • Taglierina.  
• Cutter.



MF-ROLL • Porta rotoli.  
• Roll dispenser.

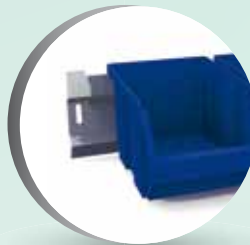

AX10 • Supporto per container.  
• Container support.



AX11 • Mensola.  
• Shelf.

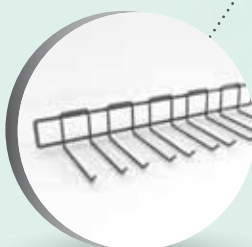

AX17 • Porta Forbici.  
• Scissors holder.



AX11-2 • Mensola doppia.  
• Double Shelf.

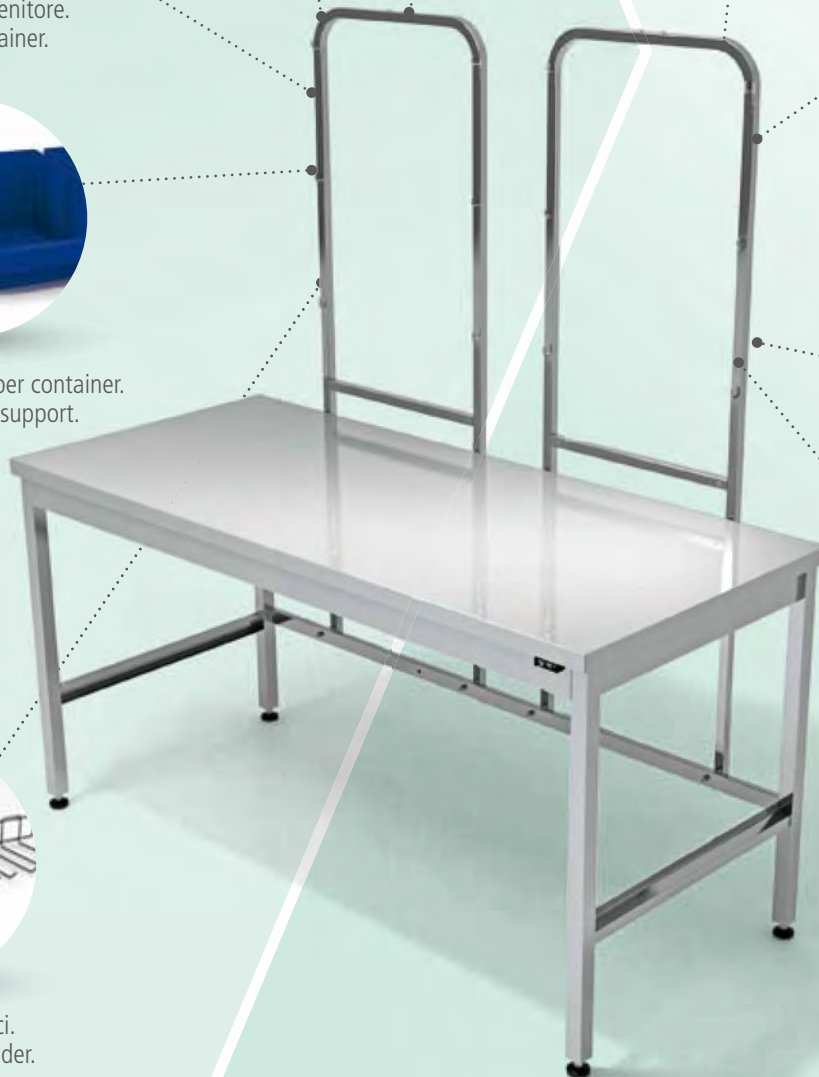

# ESEMPI DI CONFIGURAZIONE CONFIGURATION EXAMPLES



- 191AX-ELEC



- 191AX-ELEC
- MF-191



- 191AX-ELEC
- MF-191
- DR-191-1



- 191AX-ELEC
- MF-191
- DR-191-2



- 191AX-ELEC
- MF-191
- DR-191-3



- 191AX-ELEC
- MF-191
- DR-191-3
- VP-191



- 191AX-ELEC
- MF-191
- DR-191-3
- VP-191
- LGH-191



- 191AX-ELEC
- MF-191
- DR-191-3
- VP-191
- CL-191

# TAVOLI PER CONFEZIONAMENTO STRUMENTARIO STERILE TECHNICAL TABLES FOR PACKING STERILE TOOLS



OPTIONAL

- RP-191
- LS-191
- LS-191

## 191AX

- Tavolo con solo piano di lavoro.
- Table with work surface only.
- Tisch nur mit Arbeitsfläche.
- Table avec plan de travail seulement.
- Mesa sólo con encimera.

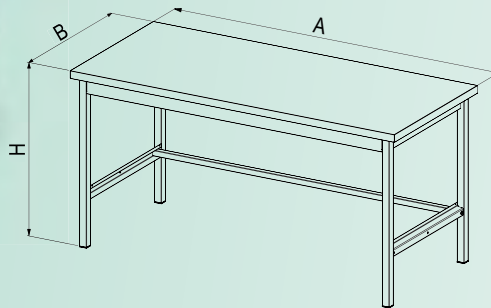

Sizes (mm)	A	B	H
<b>191AX14</b>	1400	800	900
<b>191AX16</b>	1600	800	900
<b>191AX18</b>	1800	800	900
<b>191AX20</b>	2000	800	900
<b>191AX22</b>	2200	800	900



OPTIONAL

- RP-191
- LS-191
- LS-191

## 191AXCR

- Tavolo con solo piano di lavoro su ruote.
- Table with work surface only on wheels.
- Tisch nur mit Arbeitsfläche mit Rädern.
- Table avec plan de travail seulement sur roues.
- Mesa sólo con encimera sobre ruedas.

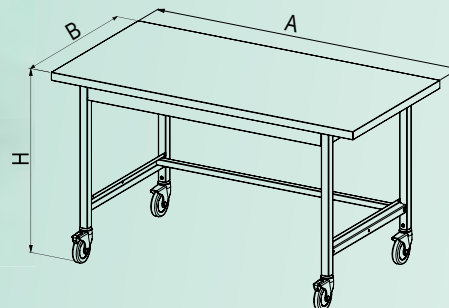

Sizes (mm)	A	B	H
<b>191AXCR14</b>	1400	800	900
<b>191AXCR16</b>	1600	800	900
<b>191AXCR18</b>	1800	800	900
<b>191AXCR20</b>	2000	800	900
<b>191AXCR22</b>	2200	800	900



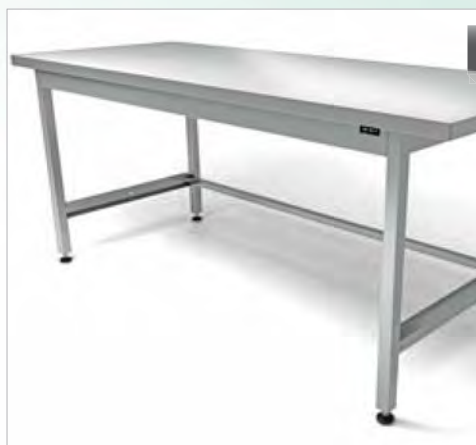

### 191AX-ELEC

- Tavolo con piano di lavoro ad elevazione oleodinamica elettrica.
- Table with electrical hydraulic height adjustable work surface.
- Tisch mit Arbeitsfläche mit elektrisch-hydraulischer Anhebung.
- Table avec plan de travail à élévation oléodynamique électrique.
- Mesa con encimera y elevación oleodinámica eléctrica.

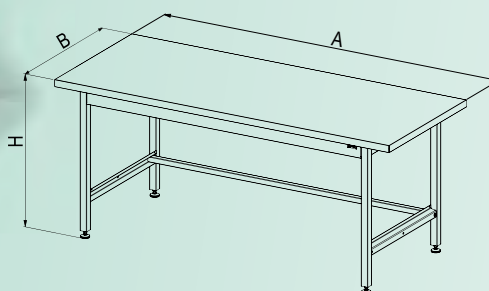

Sizes (mm)	A	B	H
191AX-ELEC14	1400	800	850->1150
191AX-ELEC16	1600	800	850->1150
191AX-ELEC18	1800	800	850->1150
191AX-ELEC20	2000	800	850->1150
191AX-ELEC22	2200	800	850->1150



### 191AXCR-ELEC

- Tavolo con piano di lavoro ad elevazione oleodinamica elettrica su ruote.
- Table with electrical hydraulic height adjustable work surface on wheels.
- Tisch mit Arbeitsfläche mit elektrisch-hydraulischer Anhebung mit Rädern.
- Table avec plan de travail à élévation oléodynamique électrique sur roues.
- Mesa con encimera y elevación oleodinámica eléctrica sobre ruedas.

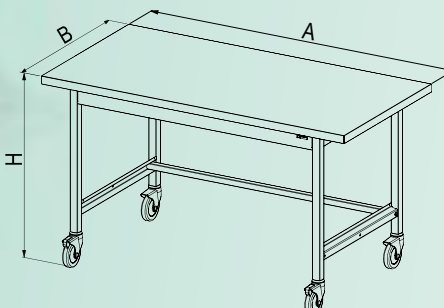

Sizes (mm)	A	B	H
191AXCR-ELEC14	1400	800	850->1150
191AXCR-ELEC16	1600	800	850->1150
191AXCR-ELEC18	1800	800	850->1150
191AXCR-ELEC20	2000	800	850->1150
191AXCR-ELEC22	2200	800	850->1150

# TAVOLI PER CONFEZIONAMENTO STRUMENTARIO STERILE TECHNICAL TABLES FOR PACKING STERILE TOOLS



## 191AX-MAN

- Tavolo con piano di lavoro ad elevazione oleodinamica manuale.
- Table with manual hydraulic height adjustable work surface.
- Tisch mit Arbeitsfläche mit manueller hydraulischer Anhebung.
- Table avec plan de travail à élévation oléodynamique manuelle.
- Mesa con encimera y elevación oleodinámica manual.

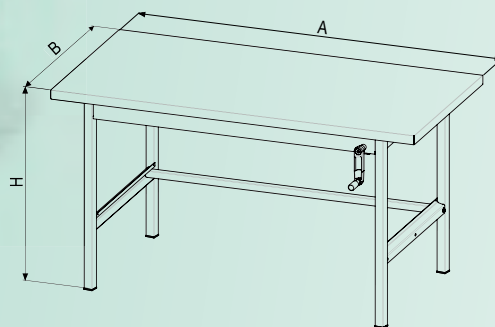

Sizes (mm)	A	B	H
<b>191AX-MAN14</b>	1400	800	800->1200
<b>191AX-MAN16</b>	1600	800	800->1200
<b>191AX-MAN18</b>	1800	800	800->1200
<b>191AX-MAN20</b>	2000	800	800->1200
<b>191AX-MAN22</b>	2200	800	800->1200

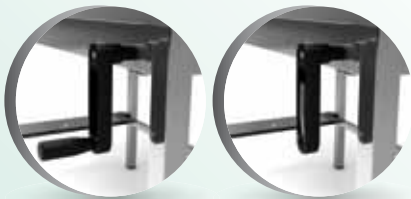

Manovella di comando regolazione altezza  
Height adjustable crank command



## 191AXCR-MAN

- Tavolo con piano di lavoro ad elevazione oleodinamica manuale su ruote.
- Table with manual hydraulic height adjustable work surface on wheels.
- Tisch mit Arbeitsfläche mit manueller hydraulischer Anhebung mit Rädern.
- Table avec plan de travail à élévation oléodynamique manuelle sur roues.
- Mesa con encimera y elevación oleodinámica manual sobre ruedas.

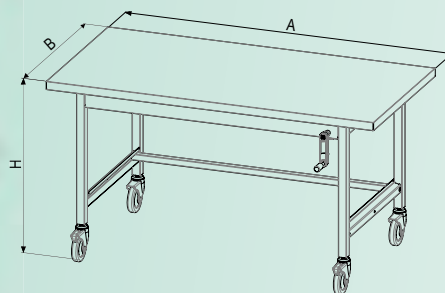

Sizes (mm)	A	B	H
<b>191AXCR-MAN14</b>	1400	800	800->1200
<b>191AXCR-MAN16</b>	1600	800	800->1200
<b>191AXCR-MAN18</b>	1800	800	800->1200
<b>191AXCR-MAN20</b>	2000	800	800->1200
<b>191AXCR-MAN22</b>	2200	800	800->1200



### CUT-191

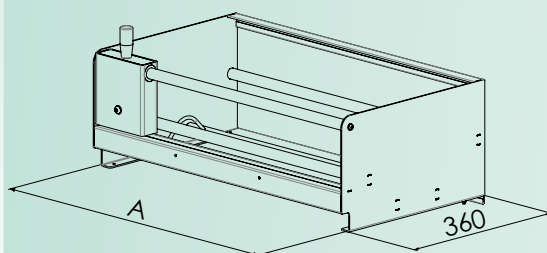

- Taglierina da banco per imbustati.
- Paper cutter with rollholder.
- Schneidvorrichtung mit Rollenhalter.
- Coupe papier de table.
- Cortadora de mesa con soporte para papel.

Sizes (mm)	A
<b>CUT-191</b>	630
<b>CUT-191-9</b>	930
<b>CUT-191-12</b>	1230
<b>CUT-191-15</b>	1530





## ARREDI PER CONFEZIONAMENTO STRUMENTARIO STERILE. TECHNICAL FURNITURE FOR PACKING STERILE TOOLS.

- Arredi destinati alla preparazione dello strumentario chirurgico da sterilizzare.
- Furnishings used for the preparation of surgical instruments to be sterilized.
- Ausstattungen für die Vorbereitung der zu sterilisierenden chirurgischen Instrumente.
- Mobilier pour la préparation des instruments chirurgicaux à stériliser.
- Mobiliario destinado a la preparación del instrumental quirúrgico por esterilizar.



 Costruiti interamente con lamiera di acciaio inox 18/10 AISI 304 (1.4301) con finitura superficiale di satinatura Scotch-Brite. Tutte le saldature vengono eseguite con procedimento TIG a garanzia di perfetta igiene e pulizia.

Angoli raggianti senza spigoli vivi, per garantire la totale incolumità degli operatori.

Piani di lavoro superiore in acciaio inox igienico e antibatterico, rinforzato nella parte inferiore con pannello fonoassorbente e antiriverbero.

Il tutto appoggia su piedini di 150 mm regolabili in altezza per un corretto livellamento dei banconi e per una facile pulizia e disinfezione della parte sottostante.

 Built entirely of 18/10 AISI 304 (1.4301) stainless steel sheet with matte Scotch-Brite surface finish. All welds are done using a TIG process to ensure perfect hygiene and cleanliness.

Rounded corners without sharp edges, to guarantee the total safety for users.

Hygienic and antibacterial stainless steel upper work surface, reinforced at the bottom with sound absorbent and anti-glare panel.

The whole unit rests on adjustable height 150 mm legs for proper leveling of the counter and for easy cleaning and disinfection of its underside.

 Vollständig hergestellt aus Edelstahlblech 18/10 AISI 304 (1.4301) mit Oberflächensatinierung Scotch-Brite. Alle Schweißarbeiten werden mit TIG-Verfahren ausgeführt, die eine perfekte Hygiene und Reinigung gewährleisten.

Abgerundete Ecken ohne scharfe Kanten, für umfassende Sicherheit der Benutzer.

Obere Arbeitsfläche aus hygienischem und antibakteriellem rostfreiem Edelstahl, im unteren Bereich mit schall- und hallschluckender Platte.

Der Komplex lagert auf höhenverstellbaren Stützfüßen mit einer Höhe von 150 mm für die korrekte Ausrichtung des Tisches und eine einfache Reinigung und Desinfektion des darunter liegenden Bereichs.



 Entièrement fabriqués en tôle d'acier inoxydable 18/10 AISI 304 (1.4301) avec finition de surface satinée Scotch-Brite. Toutes les soudures sont exécutées avec le procédé TIG pour garantir une parfaite hygiène et propreté.

Les angles arrondis et non tranchants, pour assurer la parfaite sécurité des opérateurs.

Plans de travail de qualité supérieure en acier inoxydable, hygiénique et antibactérien, avec partie inférieure renforcée par un panneau d'isolation phonique et anti-éblouissement.

Le tout repose sur des pieds de 150 mm à hauteur réglable pour un bon nivellement du comptoir et pour faciliter le nettoyage et la désinfection de la partie sous-jacente.

 Construido íntegramente con chapa de acero inoxidable 18/10 AISI 304 (1.4301) con acabado superficial de satinado Scotch-Brite. Todas las soldaduras son realizadas con procedimiento TIG que garantiza higiene excelente y limpieza.

Ángulos radiados sin aristas vivas, para garantizar la total incolumidad de los operadores.

Mostrador superior de acero inoxidable higiénico y antibacteriano, reforzado en la parte inferior con panel fonoabsorbente y anti-reverbero.

Todo ello apoyado sobre pies de 150 mm regulables en altura para una correcta nivelación del plano y para una fácil limpieza y desinfección de la pared subyacente.

# ARREDI PER CONFEZIONAMENTO STRUMENTARIO STERILE TECHNICAL FURNITURE FOR PACKING STERILE TOOLS

MISC-LC



SND-28  
SND-40



- SND-28. • Vasca di lavaggio ad ultrasuoni.  
SND-40. • Ultrasonic washing basin.  
• Ultraschall waschbecken.  
• Bassin de lavage a ultrason.  
• Bano de lavado a ultrasonidos.

- MISC-LC. • Rubinetto miscelatore a leva clinica.  
• Mixing faucet with sanitary lever.  
• Wasserhahn mit Mischer und Klinik-hebel.  
• Robinet regulateur a levier clinique.  
• Grifo mezclador con palanca clinica.

- MISC-DC. • Rubinetto con doccia.  
• Sink with extractable shower.  
• Wasserhahn mit Handbrause.  
• Robinet avec douche.  
• Grifo con Ducha.

- FS-LIQ. • Aspiraliquidi freestanding.  
• Liquid aspirator "freestanding".  
• Absauggerät für Flüssigkeiten "freistehend".  
• Aspirateur à eau freestanding.  
• Aspirador de liquidos freestanding.

- 506-LIQ. • Aspiraliquidi da banco.  
• Liquid aspirator integrated in the cabinet.  
• Integrierter Absauggerät für Flüssigkeiten.  
• Aspirateur à eau de banc.  
• Aspirador de liquidos para el banco.

- DPMR-500BT. • Dispenser igienizzatore da 500 ml automatico a batteria.  
• Automatic disinfectant dispenser 500 ml, battery operated.  
• Automatischer Desinfektionsmittelspender 500 ml, batteriebetrieben.  
• Dispenser sanitaire de 500 ml automatique (avec batterie).  
• Dispensador de desinfectante automático de 500 ml, con baterias.

- DPMR-500LC. • Dispenser igienizzatore da 500 ml con leva manuale.  
• Disinfectant dispenser 500 ml with manual lever.  
• Desinfektionsmittelspender 500 ml mit Hand Hebel.  
• Distributeur de desinfectant de 500 ml avec leveir manuel.  
• Dispensador de desinfectante de 500 ml de palanca manual.

- KUGUN-510. • Accessori per pistola ad acqua.  
• Water gun accessories.  
• Wasserpistone Zubehör.  
• Accessoires pour pistolet eau.  
• Accesorios para pistola de agua.

- GUN-510. • Pistola aria/acqua.  
• Air/Water guns.  
• Wasser-/Luftpistone.  
• Pistolets air/eau.  
• Pistola de aria/agua.

- 506-KICK. • Zocolatura.  
• Kickplate.  
• Sockelleiste.  
• Plinthe.  
• Zócalo.



506-LIQ



FS-LIQ



- Si eseguono composizioni e lavorazioni su misura per ogni specifica esigenza.
- We perform compositions and customised solutions for each specific need.
- Auf besonderer Anfrage können Zusammensetzungen und Bearbeitungen durchgeführt werden.
- Des compositions et ouvrages sur mesure sont exécutés pour chaque exigence spécifique.
- Se realizan composiciones y trabajos a medida para satisfacer los requisitos del cliente.



MISC-DC



DPMR-500LC  
DPMR-500BT

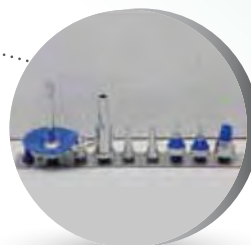

KUGUN-510



GUN-510

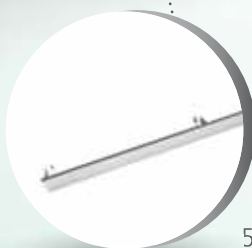

506-KICK

STRUCTURAL DETAILS:



TECHNICAL DETAILS:



SAFETY DETAILS:



# ARREDI PER CONFEZIONAMENTO STRUMENTARIO STERILE TECHNICAL FURNITURE FOR PACKING STERILE TOOLS



## 506-SKBA

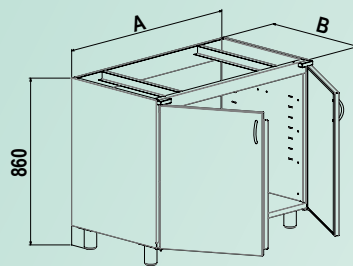

- Base contenimento lavabo con ante a battente .
- Base for basin with hinged doors.
- Waschbecken-grundgestell mit Flügeltüren.
- Base pour accueillir lavabo doté d'une porte à un battant.
- Base con lavabo con puerta de bisagras.

Sizes (mm)	A	B	H	Doors	Sink
<b>506-106SKBA</b>	1000	600	860	2	□
<b>506-107SKBA</b>	1000	700	860	2	□ / □
<b>506-126SKBA</b>	1200	600	860	2	□ □
<b>506-127SKBA</b>	1200	700	860	2	□ □ / □
<b>506-156SKBA</b>	1500	600	860	3	□ □
<b>506-157SKBA</b>	1500	700	860	3	□ □ / □ □

**510-4**   
(500x400x250 mm)

**510-5**   
(600x500x300 mm)



## 506BA

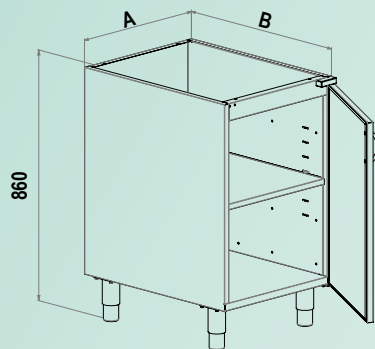

- Base con anta battente e ripiano interno regolabile in altezza.
- Basis with hinged door and height-adjustable internal shelf.
- Basis mit Flügeltür und höheneinstellbarer Innen-Regalboden.
- Base avec porte à battant et étagère interne réglable en hauteur.
- Base con puerta de bisagras y estante interno de altura ajustable.

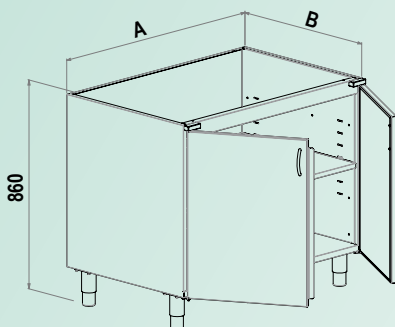

Sizes (mm)	A	B	H	Doors
<b>506-56BA*</b>	500	600	860	1
<b>506-57BA*</b>	500	700	860	1
<b>506-66BA*</b>	600	600	860	1
<b>506-67BA*</b>	600	700	860	1
<b>506-106BA</b>	1000	600	860	2
<b>506-107BA</b>	1000	700	860	2
<b>506-126BA</b>	1200	600	860	2
<b>506-127BA</b>	1200	700	860	2

\* Possibilità di montaggio porta con apertura a destra o sinistra  
Assembling availability for right or left door opening



### 506

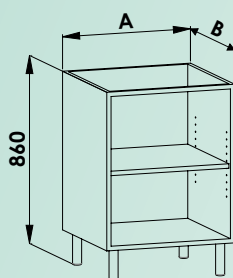

- Base aperta e ripiano interno regolabile in altezza.
- Open base and height-adjustable internal shelf.
- Offene Basis und höheneinstellbarer Innen-Regalboden.
- Base ouverte et étagère interne réglable en hauteur.
- Base abierta y estante interno de altura ajustable.

Sizes (mm)	A	B	H
506-56	500	600	860
506-57	500	700	860
506-66	600	600	860
506-67	600	700	860
506-106	1000	600	860
506-107	1000	700	860
506-126	1200	600	860
506-127	1200	700	860



### 507

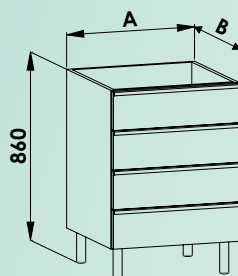

- Cassettiera con 4 cassetti.
- Drawer unit with 4 drawers.
- Kommodenschrank mit 4 Schubladen.
- Commode à 4 tiroirs.
- Unidad de cajones con 4 cajones.

Sizes (mm)	A	B	H
507-56.4	500	600	860
507-57.4	500	700	860
507-66.4	600	600	860
507-67.4	600	700	860



### 508SH

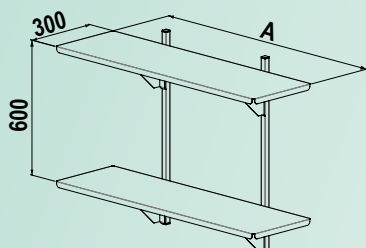

- Mensole murali.
- Wall Shelves.
- Wandregale.
- Étagères mural.
- Estantes murales.

Sizes (mm)	A	
508SH-60	600	2 post
508SH-80	800	2 post
508SH-100	1000	2 post
508SH-120	1200	2 post
508SH-160	1600	3 post
508SH-200	2000	3 post



# ARREDI PER CONFEZIONAMENTO STRUMENTARIO STERILE TECHNICAL FURNITURE FOR PACKING STERILE TOOLS



## 508

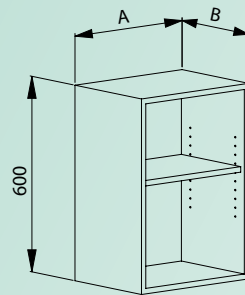

- Pensile aperto e ripiano interno regolabile in altezza.
- Open wall cabinet and height-adjustable internal shelf.
- Offener Hängeschrank und höheninstellbarer Innen-Regalboden.
- Placard mural et étagère interne réglable en hauteur.
- Armario de frente abierto con estante interno de altura ajustable.

Sizes (mm)	A	B	H
<b>508-54</b>	500	400	600
<b>508-64</b>	600	400	600
<b>508-104</b>	1000	400	600
<b>508-124</b>	1200	400	600



## 508BA

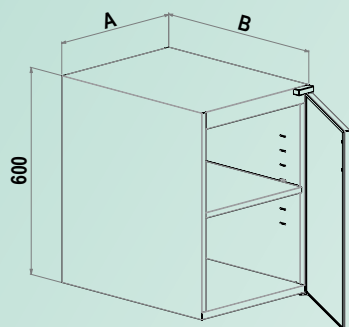

- Pensile con anta battente e ripiano interno regolabile in altezza.
- Wall cabinet with hinged door and height-adjustable internal shelf.
- Hängeschrank mit Flügeltür und höheninstellbarer Innen-Regalboden.
- Placard mural avec porte à battant et étagère interne réglable en hauteur.
- Armario de pared con puerta de bisagras y estante interno de altura ajustable.

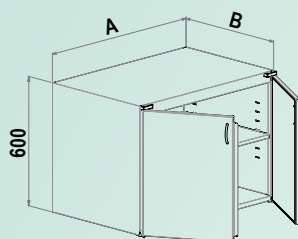

Sizes (mm)	A	B	H	Doors
<b>508-54BA</b>	500	400	600	1
<b>508-64BA</b>	600	400	600	1
<b>508-104BA</b>	1000	400	600	2
<b>508-124BA</b>	1200	400	600	2



### 508-SC

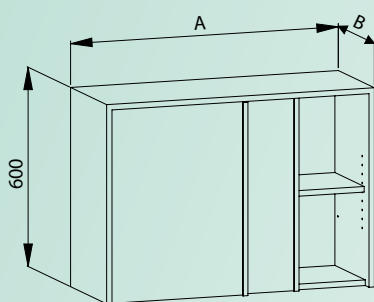

- Pienale con anta scorevole e ripiano interno regolabile in altezza.
- Wall cabinet with sliding door and height-adjustable internal shelf.
- Hängeschränk mit Schiebetür und höheneinstellbarem Innen-Regalboden.
- Placard mural avec porte coulissante et étagère interne réglable en hauteur.
- Armario de pared con puerta deslizante y estante interno de altura ajustable.

Sizes (mm)	A	B	H
<b>508-104SC</b>	1000	400	600
<b>508-124SC</b>	1200	400	600



### 509

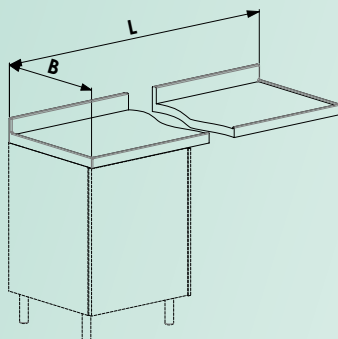

- Piano (Top) di lavoro con alzatina contenitiva a metro lineare.
- Bearing plane (Top) with linear meter containment back-guard.
- Arbeitstisch mit lfm. Aufkantung.
- Surface de travail avec rebord relevé au mètre.
- Encimera (Top) con alzada de contención por metro lineal.

Sizes (mm)	B	L
<b>509-6</b>	600	mtl
<b>509-7</b>	700	mtl



### 510

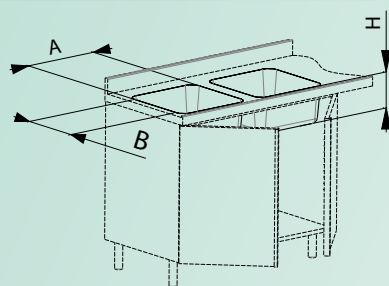

- Vasca di lavaggio completa di piletta e sifone.
- Wash basin complete with drain out and siphon.
- Waschbecken Komplett mit Abfluss und Siphon.
- Cuve de lavage avec le drain et le siphon.
- Tanque de lavado completo con desagüe y sifón.

Sizes (mm)	A	B	H
<b>510-5 S/C/D</b>	500	400	250
<b>510-4 S/C/D</b>	600	500	320



DISPOSITION S



DISPOSITION C



DISPOSITION D

## LOGISTICA PER CENTRALI DI STERILIZZAZIONE LOGISTICS FOR CSSD

- Adatti al trasporto ed allo stoccaggio di set sterili nonché adatti al servizio di logistica d'impacchettamento e gestione dei panieri grigliati utilizzati nel processo di sterilizzazione.
- Suitable for transport and storage of sterile sets and suitable for the packing logistics service and management of grated trays used in the sterilization process.
- Geeignet für den Transport und die Aufbewahrung der sterilen Sets sowie für die Verpackungslogistik und das Handling der im Sterilisierungsverfahren verwendeten Gitterkörbe.
- Convient au transport et au stockage des kits stériles et adaptés au service logistique d'emballage et de gestion des réseaux de paniers grillagés utilisés dans le processus de stérilisation.
- Aptos para el transporte y el almacenamiento de set estériles así como para el servicio de logística de empaquetado y gestión de las cestas enrejadas empleadas en el proceso de esterilización.



 Costruiti interamente con lamiera e profilati di sezione quadra e tonda di acciaio inox AISI 304 (1.4301).

Completati ed opportunamente saldati con procedimento TIG per evitare infiltrazioni e/o depositi di sporco, a garanzia di una perfetta igiene.

Finitura superficiale di elettrolucidatura di serie.

 Built entirely with sheet metal and square and round section AISI 304 (1.4301) stainless steel profiles.

Completed and suitably welded with TIG process, to avoid infiltration and/or dirt deposit, ensuring perfect hygiene.

Standard electro-polished surface finish.

 Vollständig hergestellt mit Blech und quadratischem sowie rundem Profilmaterial AISI 304 (1.4301).

Verschweißt mit TIG-Verfahren, um Infiltrationen und/oder Schmutzablagerungen zu vermeiden. Auf diese Weise wird umfassende Hygiene gewährleistet.

Serienmäßige Elektropolitur der Oberflächen.





 Entièrement fabriqués en tôle et profilés de section carrée et ronde en acier inoxydable AISI 304 (1.4301).

Dûment remplis et soudés selon le procédé TIG pour prévenir les infiltrations et / ou dépôts de saleté et garantir ainsi une hygiène parfaite.

Finition de surface standard en électro-polissage.

 Construidos íntegramente con chapa y perfiles de sección cuadrada y redonda de acero inoxidable AISI 304 (1.4301).

Completados y oportunamente soldados con el procedimiento TIG para evitar infiltraciones y/o depósitos de suciedad, para garantizar una higiene perfecta.

Acabado superficial con electropulido de serie.

# LOGISTICA PER CENTRALI DI STERILIZZAZIONE LOGISTICS FOR CSSD

OPTIONALS



### STRUCTURAL DETAILS:

**AINOX**  
304  
AISI 304



### SAFETY DETAILS:



### TECHNICAL DETAILS:



- Ruote con freno a pedale
- Wheels with pedal brake



- Ruote antistatiche
- Antistatic Wheels





AX02 • Dispenser guanti  
• Gloves dispenser

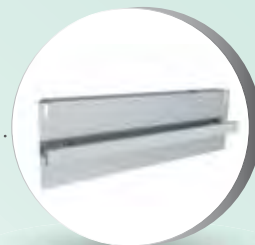

AX03 • Supporto universale.  
• Universal support.



AX04 • Porta lastre.  
• X-ray folder.



AX05 • Dispenser.  
• Tilt bins.



AX07 • Mensola contenitiva.  
• Shelf.

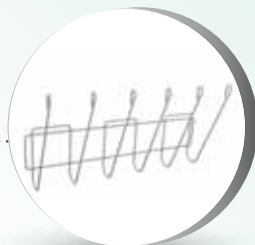

AX08 • Porta orinatoio.  
• Urine bottle holder.

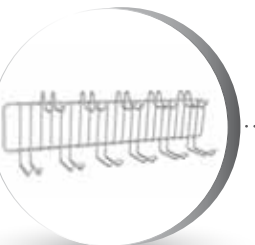

AX09 • Porta cateteri.  
• Catheter holder.



AX11 • Mensola.  
• Shelf.



AX12 • Porta padelle.  
• Bedpan holder.

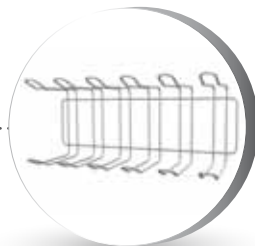

PZ • Porta zoccoli (6 paia).  
• Shoes holder (6 pair).



AX-16 • Supporto obliquo cesti.  
• Inclined basket support.

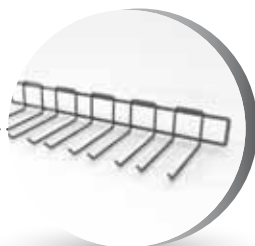

AX17 • Porta Forbici.  
• Scissors holder.



# LOGISTICA PER CENTRALI DI STERILIZZAZIONE LOGISTICS FOR CSSD



## REG

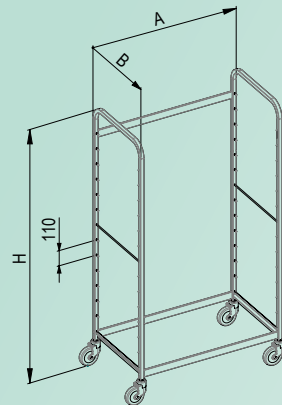

REG

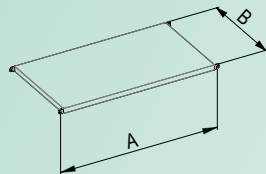

LREG

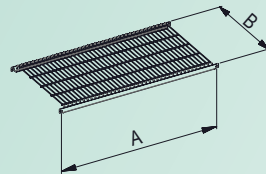

WREG

- Carrelli a scaffale composti da telaio portante e da ripiani regolabili in altezza ogni 110 mm. Disponibili in serie con ripiani in lamiera piana e/o in grigliato elettrosaldato. Ruote diam. 125 mm in gomma grigia antistraccia.
- Shelf trolleys composed of load bearing frame and shelves adjustable in height every 110 mm. Available in series with flat sheet shelves and/or welded wire shelves. 125 mm non-marking grey rubber wheels.
- Regalwagen mit tragendem Rahmen und höhenverstellbaren Regalböden jede 110 mm. Serienmäßig erhältlich mit Regalböden aus Flachblech und/oder elektrogeschweißter Gitterböden. Räder Durchm. 125 mm aus grauem Gummi mit Abriebschutz.
- Chariots constitués d'un cadre principal et de rayons à hauteur réglable tous les 110 mm. Disponibles en série avec rayons plats en tôle et / ou grille électro-soudée. Roues avec diam. de 125 mm en caoutchouc gris non tachant.
- Carros con estantes compuestos por bastidor y estantes regulables en altura cada 110 mm. Disponibles en serie con estantes de chapa plana y/o enrejado electrosoldado. Ruedas diám. 125 mm de goma gris anti-huella.

Sizes (mm)	A	B	H
<b>REG60</b>	600	600	1800
<b>LREG60</b>	600	540	-
<b>WREG60</b>	600	540	-
<b>REG100</b>	1000	600	1800
<b>LREG100</b>	1000	540	-
<b>WREG100</b>	1000	540	-
<b>REG120</b>	1200	600	1800
<b>LREG120</b>	1200	540	-
<b>WREG120</b>	1200	540	-
<b>REG140</b>	1400	600	1800
<b>LREG140</b>	1400	540	-
<b>WREG140</b>	1400	540	-



### MF - DF

#### Baskets carriage

<b>MF3</b>	3 total	3 on 1 side
<b>DF3</b>	6 total	3 on 2 sides
<b>DF4</b>	8 total	4 on 2 sides

- Adatto al trasporto di cesti ed accessori.
- Suitable for basket and accessories transport.
- Geeignet für den Transport von Körben und Zubehören.
- Convient au transport de paniers e accessoires.
- Apto para el transporte de cestas y accesorios.

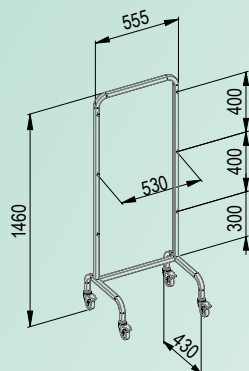

MF3

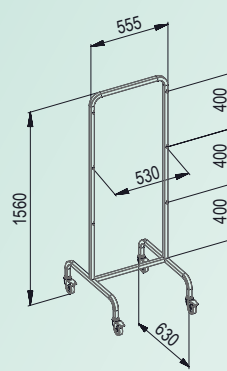

DF3

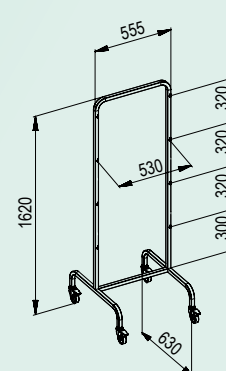

DF4



### DF2M4

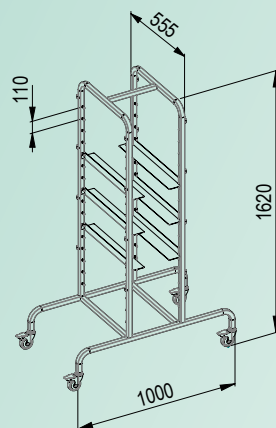

- Adatto al trasporto di n.8 cesti (4 per fronte) e di containers o panieri grigliati su n.3 coppie di guide regolabili in altezza ogni 110 mm.
- Suitable for transport of 8 baskets (4 per side) and containers or wire trays on 3 pairs of guides height adjustable every 110 mm.
- Geeignet für den Transport von 8 Körben (4 pro Seite) und Behältern oder Gitterkörben auf 3 höhenverstellbaren Schienen jede 110 mm.
- Convient au transport de 8 paniers (4 par rang) et de conteneurs ou paniers grillagés sur 3 paires de guides réglables en hauteur tous les 110 mm.
- Apto para el transporte de 8 cestas (4 por cada frente) y de contenedores o cestas enrejadas sobre 3 pares de guías regulables en altura cada 110 mm.

# LOGISTICA PER CENTRALI DI STERILIZZAZIONE LOGISTICS FOR CSSD



## MF-MR

- Supporto murale per cesti.
- Wall mounting bracket for baskets.
- Wandhalterung für Körbe.
- Support mural pour paniers.
- Soporte de pared para cestas.

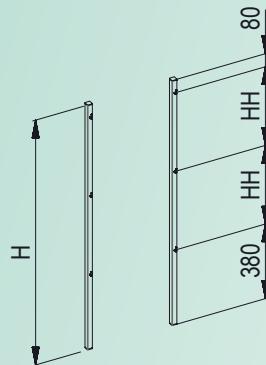

Sizes (mm)	H	HH	Pins
<b>MF4-MR22</b>	940	220	4
<b>MF5-MR22</b>	1160	220	5
<b>MF6-MR22</b>	1380	220	6
<b>MF3-MR32</b>	1020	320	3
<b>MF4-MR32</b>	1340	320	4
<b>MF5-MR32</b>	1660	320	5
<b>MF3-MR40</b>	1260	400	3
<b>MF4-MR40</b>	1660	400	4



## PT4

- Adatto al trasporto e allo stoccaggio di fogli destinati all'impacchettamento dei panierini contenenti strumentario da sterilizzare.
- Suitable for transport and storage of sheets to be used for packaging of trays containing instruments to be sterilized.
- Geeignet für den Transport und die Lagerung von Bögen für die Verpackung der Gitterkörbe, die zu sterilisierende Instrumente beinhalten.
- Convient au transport et au stockage de feuilles destinées à l'emballage des panierins contenant des instruments à stériliser.
- Apto para el transporte y el almacenamiento de hojas destinadas al empaquetado de cestas enrejadas que contienen instrumental por esterilizar.

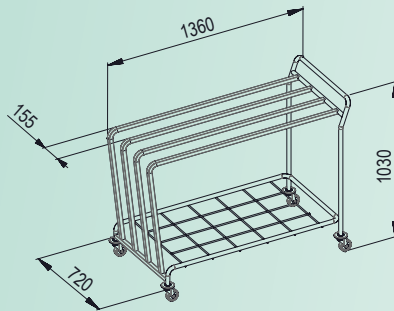

## STERICART.2

- Scaffalatura mobile per containers corredati da n.10 guide in acciaio inox fisse interasse 125 mm.
- Mobile shelving for containers with 10 fixed stainless steel guides per column center to center 125 mm.
- Regalwagen für Behälter, komplett mit 10 festen Schienenpaaren aus Edelstahl, jede 125 mm.
- Rayonnage mobile pour containers avec nr.10 guides inox fixes tous les 125 mm
- Estantería móvil para contenedores medidas equipada con 10 guías fijas de acero inoxidable por columna, interaxe 125 mm.

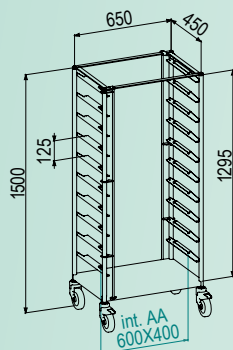





## OP-RACK

Scaffalatura mobile per containers corredata da:

- Nr. 3 coppie di acciaio inox per colonna, regolabili in altezza ogni 110 mm (versione DIN)
- Nr. 10 Coppie di guide in nylon per colonna, con passo 114 mm (versione ISO)

Mobile shelving for containers equipped with:

- Nr. 3 couple of guides in stainless steel, height adjustable every 110 mm (DIN Version)
- Nr. 10 couple of nylon guides, with distance 114 mm (ISO Version)

Mobiler Regalaufbau für Behälter, ausgestattet mit:

- Nr. 3 Schienenpaaren aus Edelstahl, pro Spalte, höhenverstellbar jede 110 mm (DIN Ausführung)
- Nr. 10 Schienenpaaren aus Nylon, pro Spalte, mit Abstand von 114 mm (ISO Ausführung)

Rayonnages mobiles pour conteneurs équipées avec :

- Nr. 3 couples de guides en acier inoxydable pour colonne, réglable en hauteur tous les 110 mm (version DIN)
- Nr. 10 Couples de guides en nylon pour colonne, avec pas 114 mm (version ISO)

Estanteria mòvil para contenedores medidas equipada con :

- Nr. 3 Parejas de guias de acero inoxidable por columna, regulables en altura cada 110 mm (Version DIN)
- Nr. 10 parejas de guias de nylon por columna, con paso de 114 mm (Version ISO)

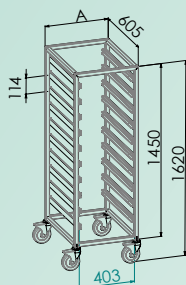

**SPRI ISO** OP-RACKI1

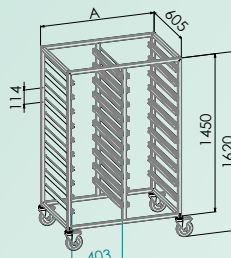

**SPRI ISO** OP-RACKI2

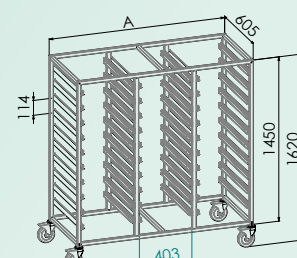

**SPRI ISO** OP-RACKI3

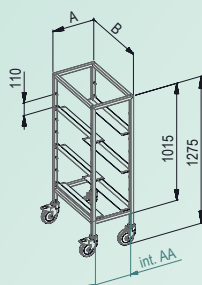

**DIN** OP-RACKD1

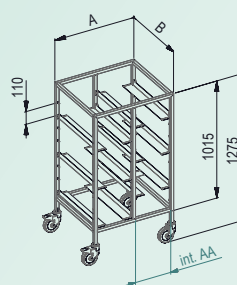

**DIN** OP-RACKD2

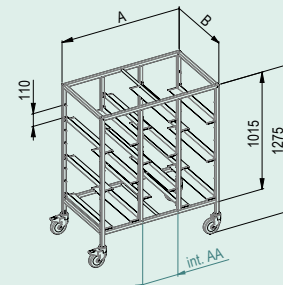

**DIN** OP-RACKD3

Sizes (mm)	A	B	AA	Suitable for
OP-RACKI1	453	600	403	600x400 ISO-SPRI
OP-RACKI2	881	600	403	600x400 ISO-SPRI
OP-RACKI3	1310	600	403	600x400 ISO-SPRI
OP-RACKD1	356	600	306	600x300 DIN
OP-RACKD2	687	600	306	600x300 DIN
OP-RACKD3	1018	600	306	600x300 DIN

## SCAFFALATURE DI DEPOSITO E STOCCAGGIO SHELVING UNITS

- Adatti allo stoccaggio di contenitori di sterilizzazione e/o cesti di contenimento di set sterili e materiale vario di confezionamento.
- Suitable for storage of sterilization containers and/or storage baskets for sterile sets and miscellaneous packaging materials.
- Geeignet für die Lagerung der Sterilisierungsbehälter und/oder Körbe für sterile Sets und verschiedenes Verpackungsmaterial.
- Adapté au stockage des conteneurs de stérilisation et: ou paniers contenant les sets stériles et matériaux divers de conditionnement.
- Aptos para el almacenamiento de contenedores de esterilización y/o el almacenamiento de cestas para equipos estériles y material de empaquetado variado.

 Struttura realizzata interamente in acciaio inox AISI 304 (1.4301) completamente saldata con procedimento TIG su tutti i punti di giunzione a garanzia di una perfetta igiene.

Il posizionamento dei ripiani e/o delle guide avviene in modo veloce e semplice senza l'ausilio di chiavi e/o utensili o del parziale smontaggio della struttura stessa.

Finitura superficiale di elettrolucidatura a lavorazione ultimata.

 Structure made entirely of stainless steel AISI 304 completely welded on all junction points with TIG process in order to guarantee perfect hygiene.

The positioning of the shelves and/or of the guides or the disassembly of structure quickly and easily place takes place without using any tools or keys.

The end the surface is finished with an electro polish process.

 Die Struktur ist völlig aus Edelstahl AISI 304 (1.4301) hergestellt. Sie ist an allen Anschweißpunkten vollkommen mit TIG-Verfahren geschweißt, dies um eine perfekte Hygiene gewährleisten zu können.

Die Positionierung der Regalbretter und/oder der Schienen oder das teilweise Abbauen der Struktur erfolgt schnell und einfach ohne Werkzeuge oder Schlüssel zu verwenden.

Als letztes kommt Oberflächenverarbeitung mittel Elektropolierung.



 Structure entièrement réalisée en acier inoxydable AISI 304 (1.4301) et complètement soudée selon procédure TIG sur tous les points de jonction afin de garantir une hygiène parfaite.

Le positionnement des étagères et / ou des rails se fait rapidement et simplement, sans clés et / ou autres outils et sans démontage partiel de la structure même.

Fourniture superficielle d'électro-polissage une fois l'ouvrage terminé.

 Estructura totalmente realizada en acero inoxidable AISI 304 (1.4301), completamente soldada con procedimiento TIG en todos los puntos de unión para garantizar una perfecta higiene.

El posicionamiento de los estantes y/o de las guías se realiza de modo veloz y sencillo sin la ayuda de llaves y/o utensilios y sin tener que desmontar parcialmente la estructura.

Acabado superficial con electropulido una vez terminada la fabricación.



# SCAFFALATURE DI DEPOSITO E STOCCAGGIO SHELVING UNITS

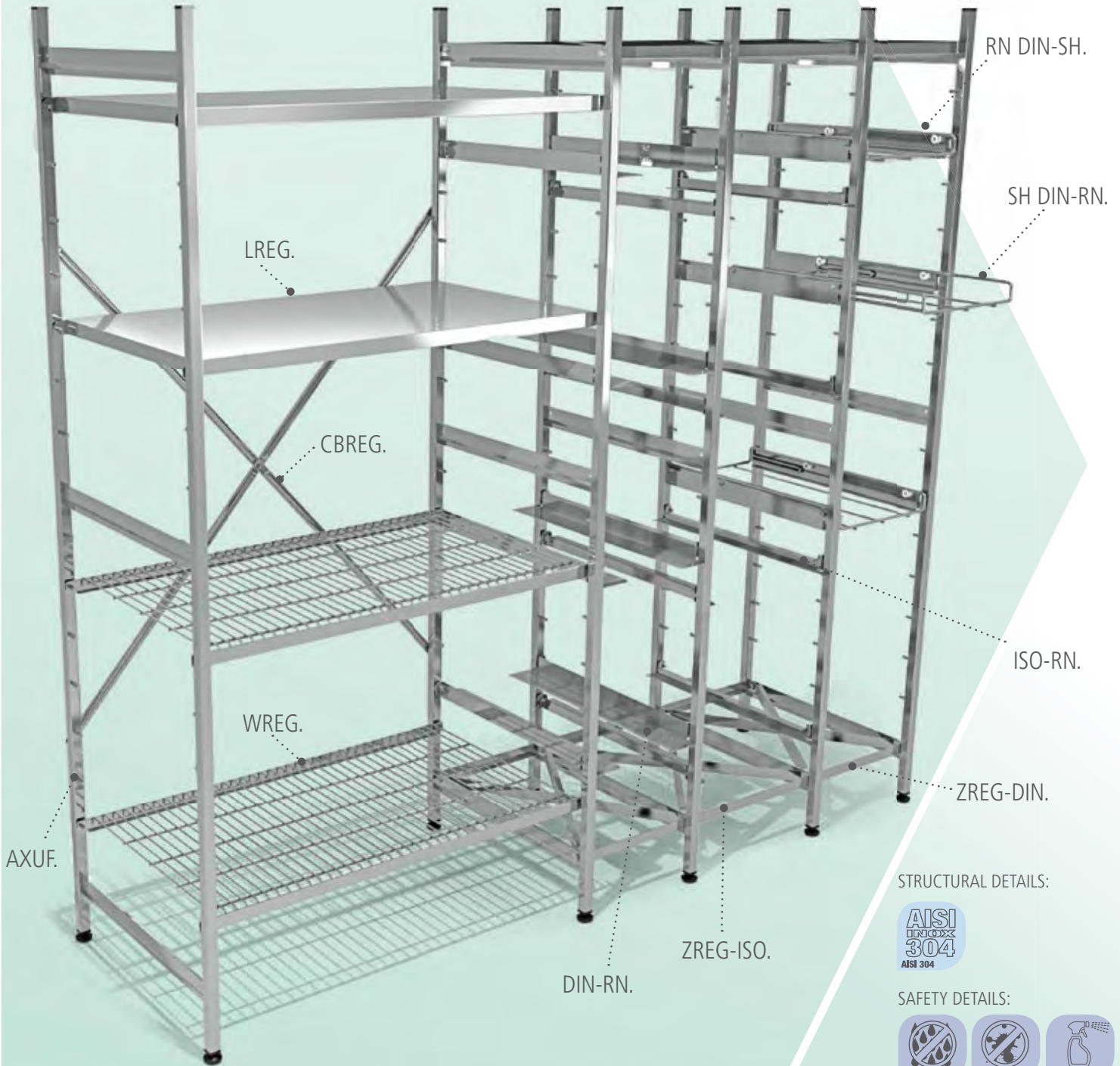

STRUCTURAL DETAILS:



SAFETY DETAILS:



TECHNICAL DETAILS:







01.

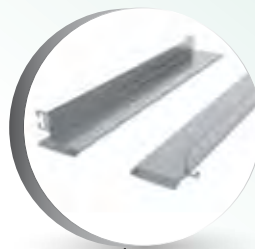

02.

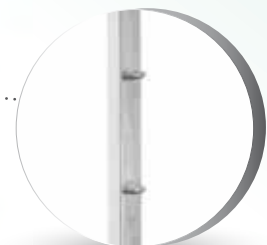

03.



04.

- 01. • Viteria in acciaio inox.  
• Stainless steel nut connection.
- 02. • Guide per container DIN.  
• DIN containers runs.
- 03. • Pin per aggancio ripiani.  
• Shelf holding pins.
- 04. • Guide per cesti ISO.  
• ISO baskets runs.
- 05. • Piedini ad altezza regolabile.  
• Height adjustable feet.



05.

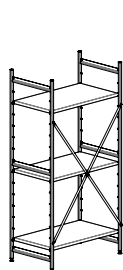

- N. 2 AXUF
- N.1 CBREG

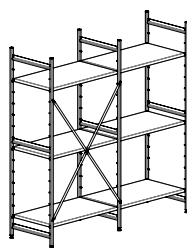

- N. 3 AXUF
- N.1 CBREG

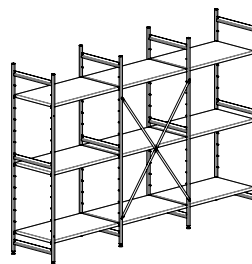

- N. 4 AXUF
- N.1 CBREG

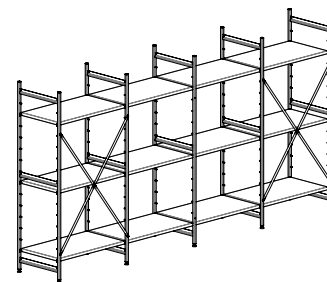

- N. 5 AXUF
- N.2 CBREG

Specifiche di montaggio  
Assembling specifications

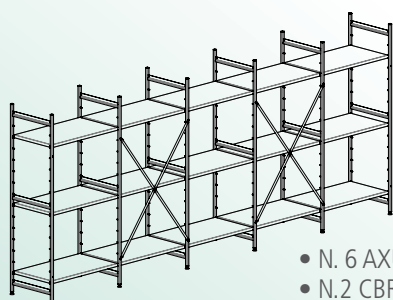

- N. 6 AXUF
- N.2 CBREG

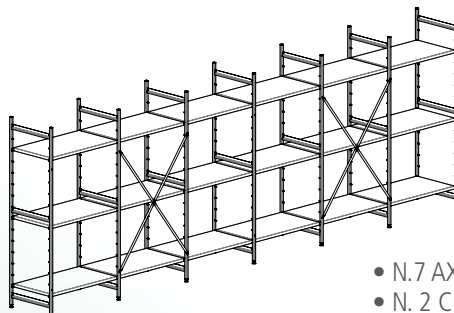

- N.7 AXUF
- N. 2 CBREG

# SCAFFALATURE DI DEPOSITO E STOCCAGGIO MOBILE MOBILE SHELVING UNITS

TPTKREG

AXUF.

TPWHE

BTPREG



## STRUCTURAL DETAILS:



## SAFETY DETAILS:



## TECHNICAL DETAILS:





## TOP-TRACK SYSTEM



## GROUND-TRACK SYSTEM

# SCAFFALATURE DI DEPOSITO E STOCCAGGIO SHELVING UNITS



ISO DIN

## AXUF

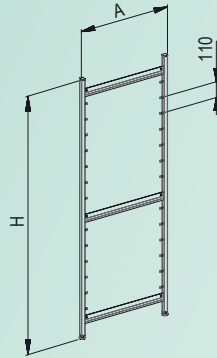

Sizes (mm)	A	B	H
AXUF20	600	-	2000
AXUF18	600	-	1800
AXUF16	600	-	1600

- Costituita da profilati quadri da 25x25 mm collegati tramite 3 barre in piatto da 50 mm. Completa di pioli laterali passo 110 mm e piedini di regolazione posti alla base.
- Consisting of 25x25 mm square sections connected by three 50 mm flat bars. Includes side pegs every 110 mm and adjustable feet on the base.
- Hergestellt aus quadratischem Profilmaterial 25x25 mm, verbunden mit 3 Stangen aus Flachstahl 50 mm. Komplet mit seitlichen Zapfen jede 110 mm und verstellbaren Füßen auf der Basis.
- Fabriqué à partir de profilés cadres de 25x25 mm raccordés par 3 barres à plat de 50 mm avec broches latérales avec pas de 110 mm et pieds de réglage à la base.
- Consistente en perfiles cuadrados de 25x25 mm conectados por barras planas de 50 mm. Incluye clavijas laterales a intervalos de 110 mm y pies ajustables en la base.



ISO DIN

## LREG

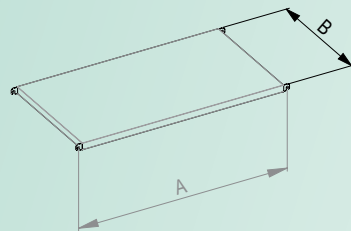

- Ripiano in lamiera piana di acciaio inox.
- Flat stainless steel sheet shelf.
- Regalboden aus Flachblech aus rostfreiem Edelstahl.
- Étagère en tôle plane en acier inoxydable.
- Estante de chapa plana de acero inoxidable.

Sizes (mm)	A	B	H
LREG100	1000	540	-
LREG120	1200	540	-
LREG140	1400	540	-



## WREG

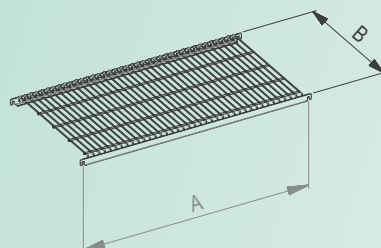

- Ripiano in filo di acciaio inox.
- Stainless steel wire shelf.
- Regalboden aus rostfreiem Edelstahldraht.
- Étagère en fil d'acier inoxydable.
- Estante de alambre de acero inoxidable.

Sizes (mm)	A	B	H
WREG100	1000	540	-
WREG120	1200	540	-
WREG140	1400	540	-



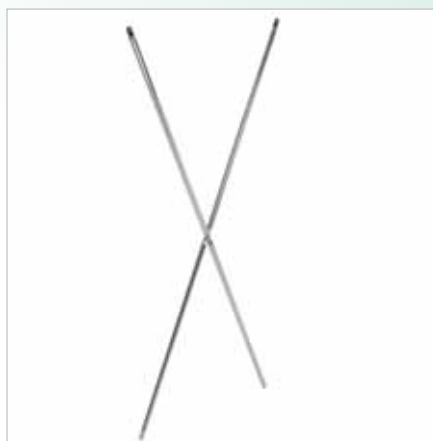

### CBREG

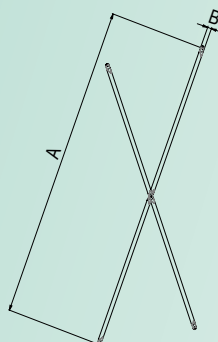

- Crociera di rinforzo per moduli a ripiani.
- Reinforcement cross brace for modules with shelves.
- Verstärkungskreuz für Module mit Regalböden.
- Tenon de renforcement pour modules à étagères.
- Abrazadera cruzada de refuerzo para módulos con estantes.

Sizes (mm)	A	B
<b>CBREG100</b>	1530	Ø 20
<b>CBREG120</b>	1668	Ø 20
<b>CBREG140</b>	1817	Ø 20

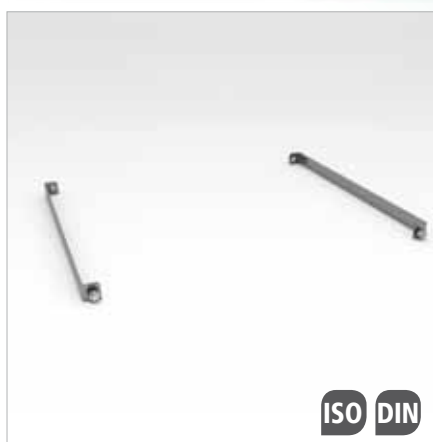

ISO DIN

### ZREG

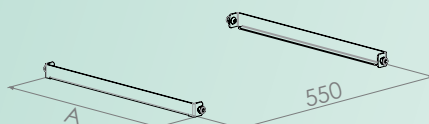

- Distanziale di rinforzo per moduli DIN e ISO
- Strengthening Spacer for ISO and DIN modules
- Verstärkungsabstandhalter für ISO und DIN Module
- Écartement de renforce pour moduls DIN et ISO
- Espaciador de reforzamiento para módulos DIN y ISO

Sizes (mm)	A
<b>ZREG-DIN</b>	330
<b>ZREG-ISO</b>	425



### TPREG

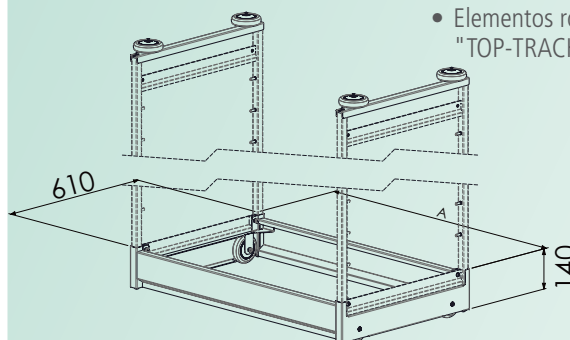

- Elementi di rotolamento per scaffalature mobili "TOP-TRACK" con ruote in gomma diam. 100 mm
- Rolling element for mobile shelving system TOP-TRACK with rubber wheels, diam 100 mm
- Rollenteil für mobile Regalsysteme TOP-RACK, mit Gummirollen, Durchm. 100 mm
- Éléments de roulement pour rayonnage mobil «TOP-TRACK» avec roues en caoutchouc diam. 100 mm
- Elementos rodantes para estanterías móviles "TOP-TRACK" con ruedas de goma diam. 100 mm

Sizes (mm)	A
<b>TPREG100</b>	1030
<b>TPREG120</b>	1230
<b>TPREG140</b>	1430

# SCAFFALATURE DI DEPOSITO E STOCCAGGIO SHELVING UNITS



ISO DIN

## GDREG

- Base di rotolamento per scaffalature mobili "GROUND TRACK" con ruote in POM diam 100 mm
- Rolling base for mobile shelving systems GROUND-RACK with POM wheels, diam. 100 mm.
- Rollenteil für mobile Regalsysteme GROUND-RACK, mit Rädern aus POM, Durchm. 100 mm
- Base de roulement pour rayonnage mobile "GROUND TRACK" avec roues en POM diam.100 mm
- Elementos rodantes para estanterías móviles "GROUND-TRACK" con ruedas de POM diam. 100 mm

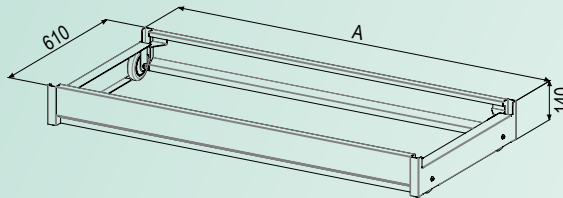

Sizes (mm)	A
<b>GDREG100</b>	1030
<b>GDREG120</b>	1230
<b>GDREG140</b>	1430



## TOP-TRACK

- Coppia di guide superiori per scaffalature TOP TRACK.
- Pair of upper runners for mobile shelving system TOP-TRACK.
- Obere Schienenpaar für mobile Regalsysteme TOP-TRACK.
- Paire de guide supérieur pour rayonnage TOP TRACK.
- Par de guías superior para estanterías móviles TOP-TRACK.

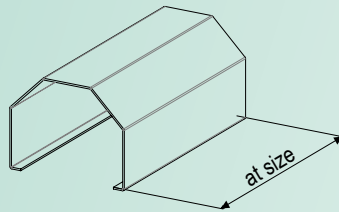

## GROUND-TRACK

- Coppia di guide inferiori per scaffalature "GROUND TRACK"
- Pair of lower runners for mobile shelving system GROUND-TRACK
- Untere Schienenpaar für mobile Regalsysteme GROUND-TRACK
- Paire de guide inférieur pour rayonnage GROUND TRACK
- Par de guías inferior para estanterías móviles GROUND-TRACK

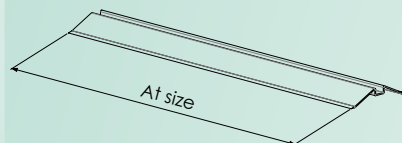



SPRI ISO

### ISO-RN

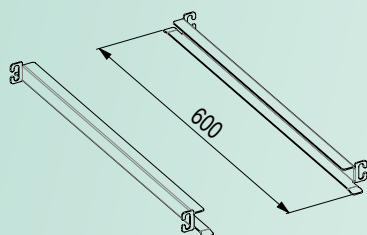

- Coppia di guide per cesti ISO.
- Pair of guides for ISO baskets.
- Schienen für ISO-Körbe.
- Paire de rails pour paniers ISO.
- Par de guías para cestas ISO.

(mm)	ISO-RN
Sizes	600



DIN

### DIN-RN

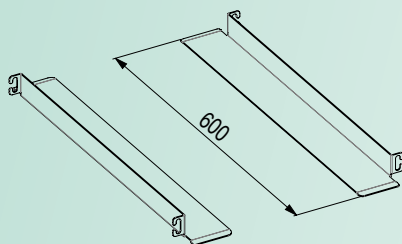

- Coppia di guide per container DIN.
- Pair of guides for DIN containers.
- Schienen für DIN-Behälter.
- Paire de rails pour conteneur DIN.
- Par de guías para contenedores DIN.

(mm)	DIN-RN
Sizes	600

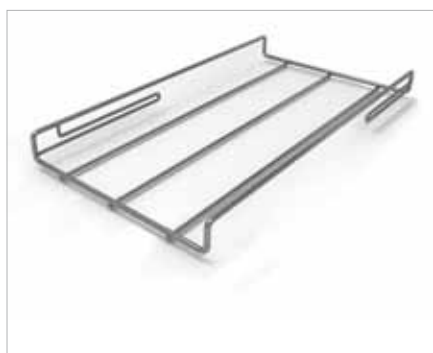

### SHDIN-RN

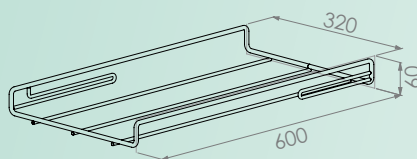

- Ripiano telescopico per container DIN.
- Telescopic shelf for DIN containers.
- Teleskopischer Regalboden für DIN Behälter.
- Rayon télescopique pour conteneur DIN.
- Estante telescopico para contenedores DIN.

(mm)	SHDIN-RN
Sizes	600



### RNDIN-SH

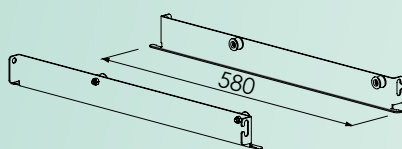

- Coppia di guide per ripiano telescopico.
- Pair of guides for telescopic shelf.
- Schienenpaar für teleskopischen Regalboden.
- Paire de rails pour rayon télescopique.
- Par de guías para estantes telescopicos.

(mm)	RNDIN-SN
Sizes	580

## SCAFFALATURE DI DEPOSITO E STOCCAGGIO SHELVING UNITS

 Struttura realizzata interamente con profilati di lega leggera anodizzata. Composto da montanti verticali laterali perforati, con interasse verticale di mm. 68, per il posizionamento a piacere delle guide porta contenitori e/o dei supporti porta ripiani.

Due sono le dimensioni standardizzate dei montanti verticali: da 600 mm (deposito ed asportazione del contenitore sul lato da 400 mm) da 400 mm (deposito ed asportazione del contenitore sul lato da 600 mm).

I montanti verticali sono provvisti di piedini regolabili nella parte terminale inferiore. Il collegamento dei montanti verticali a mezzo dei set distanziatori, permettono la formazione a piacere, di scaffalature di lunghezza desiderata, composta da moduli differenti secondo necessità.

 Structure realised completely with anodised light alloy profiles. Composed of vertical perforated lateral posts with centres mm 68 distance for positioning of guides and/or shelve placement as required.

Two standardized vertical post sizes from 600mm (side basket storage and removal for 400 mm) from 400 mm (side basket storage and removal for 600 mm).

The vertical posts on lower terminal part are provided with adjustable pins for height. Vertical post connection for all shelving requirements.

 Struktur komplett aus eloxierten Leichtmetall-Profilen. Bestehend aus perforierten senkrechten Pfosten, mit einem Abstand von 68 mm, zur gewünschten Behälter/Fächer Positionierung.

Serienausstattung mit zwei Pfosten-Abmessungen: 600 mm (Lagerung und Entfernung der Behälter auf der 400 mm Seite) und 400 mm (Lagerung und Entfernung der Behälter auf der 600 mm Seite). Die Pfosten sind ausgestattet mit regulierbaren Füßchen. Die Verbindungen der Pfosten erhält man mittels Abstand-Sets. Sie erlauben die Regalaufstellung in der gewünschten Länge, bestehend aus verschiedenen Modulen wie sie für notwendig gehalten werden.

 Structure entièrement réalisée en profilés d'alliage léger anodisés. Composé de montants verticaux latéraux perforés, avec entraxe verticale de 68 mm, permettant de positionner des guides porte-bacs et/ou des supports porte-étagères.

Deux dimensions de montants verticaux sont possibles soit de 600 (dépôt et enlèvement du bac sur le côté de 400) ou soit de 400 (dépôt et enlèvement du bac sur le côté de 600).

Les montants verticaux sont équipés de vérins à hauteur réglable. Les montants sont renforcés par des sets d'espacement (vendu en kit) permettant la juxtaposition à volonté de rayonnage.

 Estructura completamente realizada con perfiles de aleación ligera anodizada. Compuesta por montantes verticales laterales perforados, con un espacio entre estantes de 68 mm.

Existen dos posibilidades a la hora de colocar los cestos; por el lado de 600 mm o por el lado de 400 mm.

La estructura dispone de niveladores regulables. Las conexiones entre los montantes verticales se realiza con sets de interespacios, que permiten la formación de estantes del largo deseado, compuesto por diferentes módulos según necesidades.

### STRUCTURAL DETAILS:



### SAFETY DETAILS:



### TECHNICAL DETAILS:







UFRUN-IK

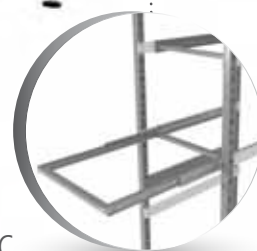

UFTLC



UFRR

- 1. • UFPT
- 2. • UFDIS
- 3. • UFRUN
- 4. • UFSH

# SCAFFALATURE DI DEPOSITO E STOCCAGGIO SHELVING UNITS



## UFPT

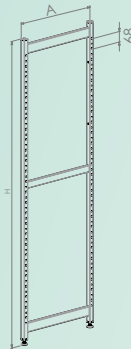

- Spalla in profilato quadro da 30x30 mm.
- 30X30 mm square section frame.
- Schulterstück aus quadratischem Profilmaterial 30x30 mm.
- Épaulement en profilé cadre de 30x30 mm.
- Bastidor de perfil cuadrado de 30x30 mm.

Sizes (mm)	A	H
<b>UFPT-60</b>	630	2140
<b>UFPT-40</b>	430	2140

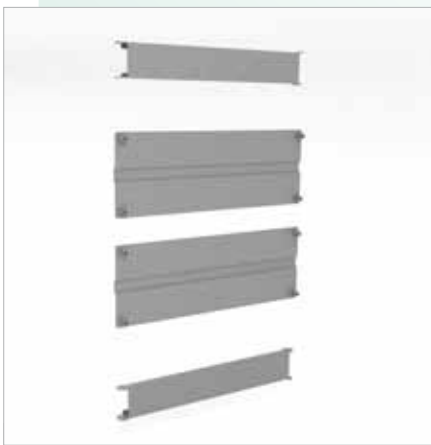

## UFDIS

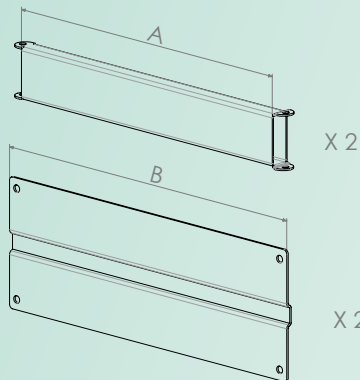

- Set distanziatore.
- Spacer set.
- Set Abstandhalter.
- Jeu de tétons d'espacement
- Set espaciador.

Sizes (mm)	A	B
<b>UFDIS-30</b>	330	375
<b>UFDIS-40</b>	420	465
<b>UFDIS-60</b>	620	665
<b>UFDIS-80</b>	865	920
<b>UFDIS-100</b>	1020	1070
<b>UFDIS-120</b>	1220	1270



## UFRUN

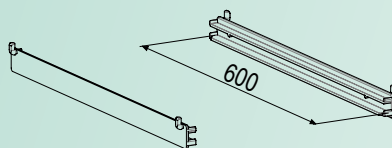

- Coppia di guide ISO in policarbonato.
- Pair of polycarbonate ISO guides.
- Führungspaar ISO aus Polycarbonat.
- Paire de rails ISO en polycarbonate.
- Par de guías ISO de policarbonato.

Sizes (mm)	A
<b>UFRUN-60</b>	600



### UFSH

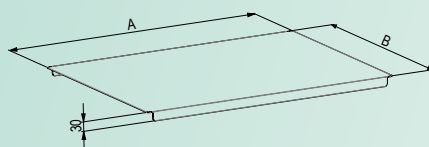

- Ripiano in lamiera piana.
- Plate shelf.
- Blechboden.
- Étagère en tôle plane.
- Estantes planos.

Sizes (mm)	A	B
<b>UFSH-40</b>	400	600
<b>UFSH-80</b>	845	600
<b>UFSH-100</b>	1000	600
<b>UFSH-120</b>	1200	600





## PANIERI GRIGLIATI, CONTENITORI E RIPIANI BASKETS, CONTAINERS AND SHELVES

- Cesti, contenitori, scaffali ausiliari per logistica di sterilizzazione.
- Baskets, containers, auxiliary shelves for sterilization logistics.
- Körbe, Behälter, Hilfsregale für die Sterilisierungslogistik.
- Paniers, conteneurs, étagères auxiliaires pour logistique auxiliaires de stérilisation.
- Cestas, contenedores, estanterías auxiliares para logística de esterilización.



### INOX LINE

Costruiti interamente in filo di acciaio inox AISI 304 (1.4301) sovrapponibili a pieno ed a vuoto. Corpo in un solo pezzo di rete opportunamente ripiegato e perfettamente saldato all'anello superiore. Anello inferiore di base chiuso per evitare punti d'appiglio e per rinforzo del fondo. Completi di maniglie di presa poste alle testate.

### PLASTIC LINE

Contenitori in policarbonato PC misure ISONORM. Con pareti laterali perforate. Bordo perimetrale per il posizionamento su guide. Inseribili a vuoto uno dentro l'altro.



### INOX LINE

Built entirely in AISI 304 (1.4301) stainless steel wire, stackable full and empty. Body made of a single piece of net suitably bent and perfectly welded to the upper ring. Closed bottom base ring to avoid snagging points and to reinforce the bottom. Equipped with handles on the ends.

### PLASTIC LINE

ISONORM sized PC polycarbonate containers. With perforated side panels. External edge for setting on guides. Stackable when empty.



### INOX LINE

Vollständig hergestellt aus Edelstahlraht AISI 304 (1.4301), im vollen und im leeren Zustand stapelbar. Körper aus einem einzigen entsprechend gebogenen Gitterstück, mit perfekter Schweißung im oberen Ring. Unterer Basisring geschlossen, für die Verstärkung des Bodens und die Vermeidung von Aufhängestellen. Komplett mit Haltegriffen an den Kopfbereichen.

### PLASTIC LINE

Behälter aus Polycarbonat PC Maß ISO-NORM. Mit perforierten Seitenwänden. Rand für Positionierung auf Führungen. Im Leerzustand ineinander stapelbar.





 INOX LINE

Entièrement fabriqués en fil d'acier inoxydable AISI 304 (1.4301) surimposables en charge et à vide. Corps monobloc en filet convenablement plié et parfaitement soudé à la bague supérieure. Bague inférieure de base fermée pour éviter les points d'ancrage et pour renforcer le fond. Livrés avec poignées placées au niveau des têtes.

PLASTIC LINE

Conteneurs en polycarbonate PC à mesures ISONORM. Avec parois latérales perforées. Bordure pour positionnement sur guides. Encastrables les uns dans les autres.

 INOX LINE

Construidos íntegramente en alambre de acero inoxidable AISI 304 (1.4301) superponibles llenos o vacíos. Cuerpo en una sola pieza de red oportunamente replegada y perfectamente soldada en el anillo superior. Anillo inferior de base cerrado para evitar puntos de enganche y como refuerzo del fondo. Dotados de manijas colocadas en los extremos.

PLASTIC LINE

Contenedores de polycarbonato PC medidas ISONORM. Con paredes laterales perforadas. Borde perimetral para el posicionamiento sobre guías. Insertables vacíos uno dentro de otro.

# PANIERI GRIGLIATI, CONTENITORI E RIPIANI BASKETS, CONTAINERS AND SHELVES



## K2-1/1

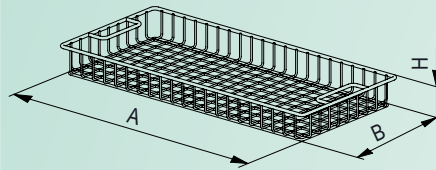

- Paniere in filo inox.
- Stainless steel wire tray.
- Gitterkorb aus Draht aus rostfreiem Edelstahl.
- Panier en fil d'acier inoxydable.
- Cestas enrejadas de alambre de acero inoxidable.

Sizes (mm)	A	B	H
K2-461	540	250	50
K2-463	540	250	100
K3-460	540	250	Cover
K2-451	480	250	50
K2-453	480	250	100
K3-450	480	250	Cover



## K2-3/4

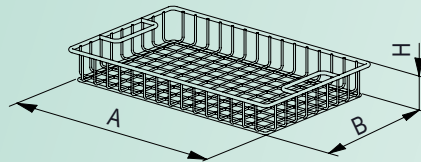

- Paniere in filo inox.
- Stainless steel wire tray.
- Gitterkorb aus Draht aus rostfreiem Edelstahl.
- Panier en fil d'acier inoxydable.
- Cestas enrejadas de alambre de acero inoxidable.

Sizes (mm)	A	B	H
K2-1501	405	250	50
K2-1503	405	250	100
K3-1500	405	250	Cover



## K2-1/2

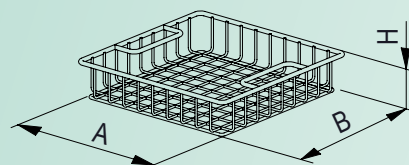

- Paniere in filo inox.
- Stainless steel wire tray.
- Gitterkorb aus Draht aus rostfreiem Edelstahl.
- Panier en fil d'acier inoxydable.
- Cestas enrejadas de alambre de acero inoxidable.

Sizes (mm)	A	B	H
K2-491	255	250	50
K2-493	255	250	100
K3-490	255	250	Cover



DIN

### CE

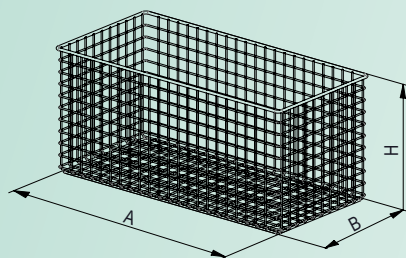

- Cesto in filo inox.
- Stainless steel wire basket.
- Korb aus Draht aus rostfreiem Edelstahl.
- Panier en fil d'acier inoxydable.
- Cesta de alambre de acero inoxidable.

Sizes (mm)	A	B	H
CE13	575	275	130
CE26	575	275	260



DIN

### CE26 1/2

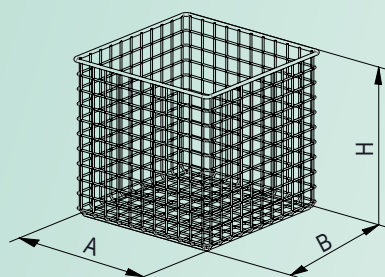

- Cesto in filo inox.
- Stainless steel wire basket.
- Korb aus Draht aus rostfreiem Edelstahl.
- Panier en fil d'acier inoxydable.
- Cesta de alambre de acero inoxidable.

Sizes (mm)	A	B	H
CE26 1/2	275	275	260



DIN

### CE26 W

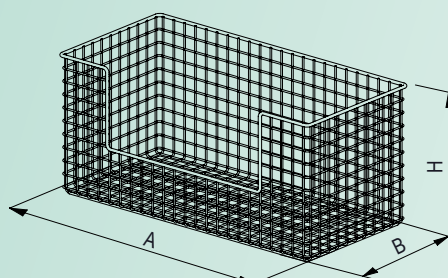

- Cesto in filo inox con finestra.
- Stainless steel wire basket with window.
- Korb aus Draht aus rostfreiem Edelstahl mit vorderer Öffnung.
- Panier en fil d'acier inoxydable avec fenêtre.
- Cesta de alambre de acero inoxidable con abertura frontal.

Sizes (mm)	A	B	H
CE26W	575	275	260



# PANIERI GRIGLIATI, CONTENITORI E RIPIANI BASKETS, CONTAINERS AND SHELVES



SPRI

## ISO6040

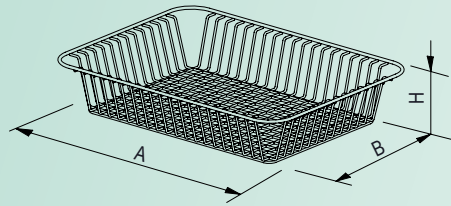

- Cesto ISO in filo inox.
- ISO stainless steel wire basket.
- ISO-Korb aus Draht aus rostfreiem Edelstahl.
- Panier ISO en fil d'acier inoxydable.
- Cesta ISO de alambre de acero inoxidable.

Sizes (mm)	A	B	H
<b>ISO604010</b>	400	600	100
<b>ISO604013</b>	400	600	130
<b>ISO604020</b>	400	600	200



DIN

## DIN-SHELF

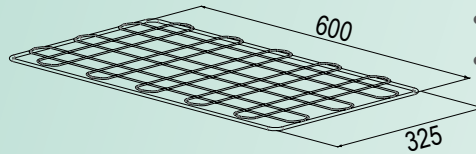

- Ripiano DIN in filo inox.
- DIN stainless steel wire shelf.
- DIN-Regalboden aus Draht aus rostfreiem Edelstahl.
- Rayon DIN en fil d'acier inoxydable.
- Estante DIN en alambre de acero inoxidable.

Dimensions: 325 x 600 mm



ISO

## ISO-SHELF

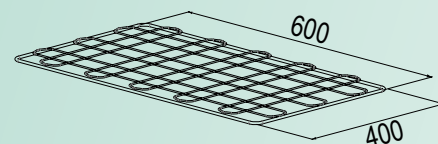

- Ripiano ISO in filo inox.
- ISO stainless steel wire shelf.
- ISO-Regalboden aus Draht aus rostfreiem Edelstahl.
- Rayon ISO en fil d'acier inoxydable.
- Estante ISO en alambre de acero inoxidable.

Dimensions: 400 x 600 mm



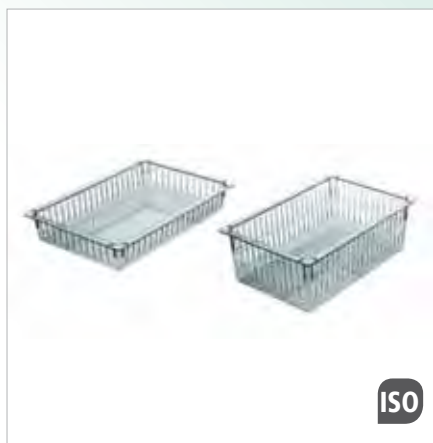

ISO

### BAC6040

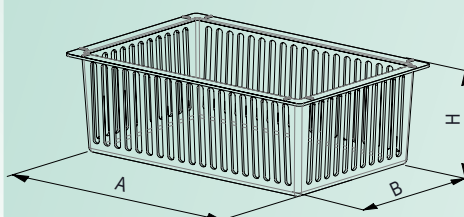

- Contenitore ISO in policarbonato.
- ISO polycarbonate container.
- ISO-Behälter aus Polykarbonat.
- Conteneur ISO en polycarbonate.
- Contenedor ISO de policarbonato.

Sizes (mm)	A	B	H
<b>BAC604005</b>	600	400	50
<b>BAC604010</b>	600	400	100
<b>BAC604020</b>	600	400	200



ISO

### PPN

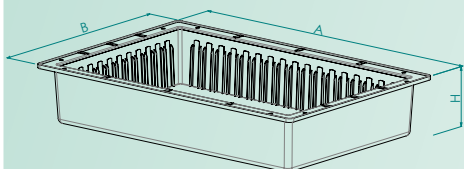

- Contenitore ISO in polipropilene.
- ISO polypropylene container.
- ISO-Behälter aus Polypropylen.
- Conteneur ISO en Polypropylène.
- Contenedor ISO de polipropileno.

Sizes (mm)	A	B	H
<b>PPN604005</b>	600	400	50
<b>PPN604010</b>	600	400	100
<b>PPN604020</b>	600	400	200



ISO

### PPF

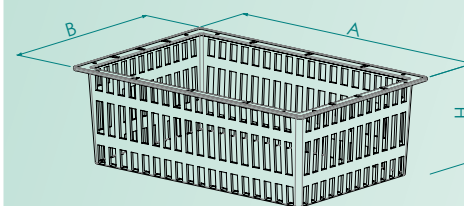

- Contenitore ISO in polipropilene.
- ISO polypropylene container.
- ISO-Behälter aus Polypropylen.
- Conteneur ISO en Polypropylène.
- Contenedor ISO de polipropileno.

Sizes (mm)	A	B	H
<b>PPF604005</b>	600	400	50
<b>PPF604010</b>	600	400	100
<b>PPF604020</b>	600	400	200



- L01**
- PORTA SACCO
  - CARRELLI DA CORSAIA
  - CARRELLI ARMADIO PER TRASPORTO DI BIANCHERIA PULITA
  - CARRELLI PER TRASPORTO DI BIANCHERIA SPORCA
  - CARRELLI IN LEGA LEGGERA PER MOVIMENTAZIONE INTERNA
  - CARRELLI IN POLIPROPILENE PER MOVIMENTAZIONE INTERNA
  - BAG HOLDERS
  - AISLE TROLLEYS
  - TROLLEYS FOR CLEAN LINEN TRANSPORT
  - TROLLEYS FOR DIRTY LINEN TRANSPORT
  - TROLLEYS IN LIGHT ALLOY FOR INTERNAL LAUNDRY HANDLING
  - POLYPROPYLENE TROLLEYS FOR INTERNAL HANDLING



- M01**
- TAVOLI PER CONFEZIONAMENTO STRUMENTARIO STERILE
  - ARREDI PER CONFEZIONAMENTO STRUMENTARIO STERILE
  - LOGISTICA PER CENTRALI DI STERILIZZAZIONE
  - SCAFFALATURA DI DEPOSITO E STOCCAGGIO
  - PANIERI GRIGLIATI, CONTENITORI E RIPIANI
  - STERILE INSTRUMENT PACKAGING TABLES
  - STERILE INSTRUMENT PACKAGING FURNITURE
  - CSSD LOGISTIC
  - SHELVING FOR STORAGE
  - BASKETS, CONTAINERS AND SHELVES



- M02**
- ARMADI DI DEPOSITO E STOCCAGGIO
  - CARRELLI ARMADIO PER TRASPORTO STRUMENTARIO
  - ARMADI PASSANTI
  - CABINETS FOR STORAGE
  - MOBILE INSTRUMENT CABINETS
  - PASS THROUGH CABINETS



- M03**
- ARREDO PRE SALA OPERATORIA
  - LOGISTICA PER SALA OPERATORIA
  - SGABELLI E SELLE
  - CARRELLI PER TRASPORTO FARMACEUTICO
  - CARRELLI GESTIONE RIFIUTI OSPEDALIERI
  - PRE-SURGICAL FURNITURE THEATRE
  - SURGICAL THEATRE LOGISTICS
  - STOOLS & SADDLES
  - PHARMACEUTICAL TRANSPORT TROLLEYS
  - WASTE MANAGEMENT TROLLEYS

